

fireline™



PUREVISION™ STOVES



Freestanding Stove Range inc Countryman PV5S 5kW Slimline, PV5 5kW, PV5W 5kW Wide, PV5WS 5kW Slimline & PV85 8.5kW Nominal Output

Installation and Operating Instructions

Please hand these instructions to the stove user when the installation is complete. Leave the stove ready for operation and instruct the user in the correct use of the appliance and operation of controls.

Important: - **These products must be installed by a suitably qualified installer.**

Clean Air Act Exemption

The **Purevision PV5S 5Kw Slimline, Purevision PV5 5kW, Purevision PV5S Slimline Countryman 5kW, Purevision PV5 Countryman 5kW, Purevision PV5W 5kw Wide, Purevision PV5W Countryman 5kW Wide, Purevision PV5WS 5kW Wide Slimline, Purevision PV5WS Countryman 5kW Wide Slimline and Purevision PV85 8.5kW** stoves only have been exempted under the Clean Air Act 1993 to burn seasoned wood logs in designated smokeless zones in the UK. This is subject to the correct fitting of the air control plate (the part and fitting instructions are packed separately) maintaining the air wash control at a minimum opening at all times. **Instructions for wood burning MUST be followed in order to ensure compliance at all times.**



Fireline – A division of: Charlton & Jenrick Ltd
Unit D Stafford Park 2, Telford, Shropshire, TF3 3AR
T: 01952 200 444 F: 01952 200480
www.charltonandjenrick.co.uk
A Charlton and Jenrick Group Company



PLEASE READ ALL THESE INSTRUCTIONS CAREFULLY!

For safety reasons it is essential that your stove is correctly installed and operated. Fireline cannot accept responsibility for any fault or consequential problems arising through incorrect installation or operation.

TABLE OF CONTENTS

Section	Page No
1. List of Components.....	4
2. Component Identification and Controls.....	4
3. Preparation of Stove for Installation.....	5
4. Important Safety Information.....	6
4.1 Warnings and important safety information.....	6
4.1.1 Instructions.....	6
4.1.2 Chimney Warning.....	6
4.1.3 Extractor Fan Warning.....	6
4.1.4 Cleaning & Chimney Sweeping.....	6
4.1.5 Fuels.....	7
4.1.6 Maintenance.....	7
4.1.7 Ventilation.....	7
4.2 Health and Safety Information.....	7
4.2.1 Handling.....	7
4.2.2 Fire Cement.....	7
4.2.3 Asbestos.....	7
4.2.4 Metal Parts.....	7
5. Installation Information.....	7
5.1 Chimney & Flue.....	7
5.2 Ventilation.....	8
5.3 Direct Outside Air Connection.....	8
5.4 Flue Draught.....	8
5.5 Connection to Chimney.....	8
5.6 Material Clearance Dimensions.....	9
5.6.1 Distances from Combustible Materials.....	9
5.6.2 Distances from Non Combustible Materials.....	10
5.7 Hearths.....	10
5.8 Accessories.....	10
5.9 Commissioning & Handover.....	10
6. Technical Data & DoP & DoC.....	12

Cont'd.....

7. Operating Instructions.....	13
7.1 Safety Notes for your guidance.....	13
7.1.1 Fireguards.....	13
7.1.2 Modifications.....	13
7.1.3 Overfiring.....	13
7.1.4 Fume Emission.....	13
7.1.5 Chimney Fire.....	13
7.1.6 CO Alarms.....	13
7.2 Warnings.....	14
7.3 Clean Air Act (Smoke Control Zones).....	14
7.4 Air controls.....	15
7.4.1 Single Air Control.....	15
7.4.2 Air Wash.....	15
7.4.3 Tertiary Air.....	15
7.4.4 Multifuel Grate.....	16
7.4.5 Ashpan.....	16
7.5 Cleaning.....	16
7.6 Fuels.....	16
7.7 Important Notes for Wood Burning.....	17
7.7.1 Refuelling on to a low Firebed.....	17
7.7.2 Fuel Overloading.....	17
7.7.3 Operation with Door Left Open.....	17
7.7.4 Primary Air Left Open.....	17
7.8 Notes on Smokeless fuel (Maxibrite) burning.....	18
7.9 Lighting the stove.....	18
7.10 Re-fuelling.....	19
7.11 Shutting down.....	19
7.12 Shutting down for prolonged periods.....	20
7.13 User Maintenance.....	20
8. Active Baffle System.....	21
8.1 Description.....	21
8.2 Operation.....	21
8.3 Adjustment.....	22
8.4 Removable Sections.....	22
9. Maintenance Guide.....	23
9.1 Removing Top Plate.....	23
9.2 Removing Door.....	23
9.3 Removing Baffle Plate.....	24
9.4 Removing Firebox Liners & Fuel Retainer.....	24
9.5 Removing Grate Components.....	25
9.6 Removing Flue Spigot Collar.....	26
9.7 Removing Outer Casing.....	26
9.8 Door Hinge Adjustment.....	27
9.9 Smoke Control Air Limiter Bracket.....	27
9.10 Air Valve Maintenance.....	28

Cont'd.....

9.11 Adjusting Door Latches.....	28
9.12 Adjusting Latch Pins.....	29
10. Dimensions.....	30
10.1 Purevision 5 Slimline.....	30
10.2 Purevision 5.....	31
10.3 Purevision 5 Wide.....	32
10.4 Purevision 5 Wide Slimline.....	33
10.5 Purevision 8.5.....	34
11. Frequently Asked Questions.....	35

2.0 Component Identification and Controls

List of Components

Description of Parts	Qty
Purevision Stove Assembly	1
Operating Tool & Stand	1
Ash Pan	1
Flue Spigot Collar (installed)	1
Casing Blanking Plate (installed)	1
Stove Operating Gloves	1
Purevision Toolkit	1

Fig 1. Operating Tool

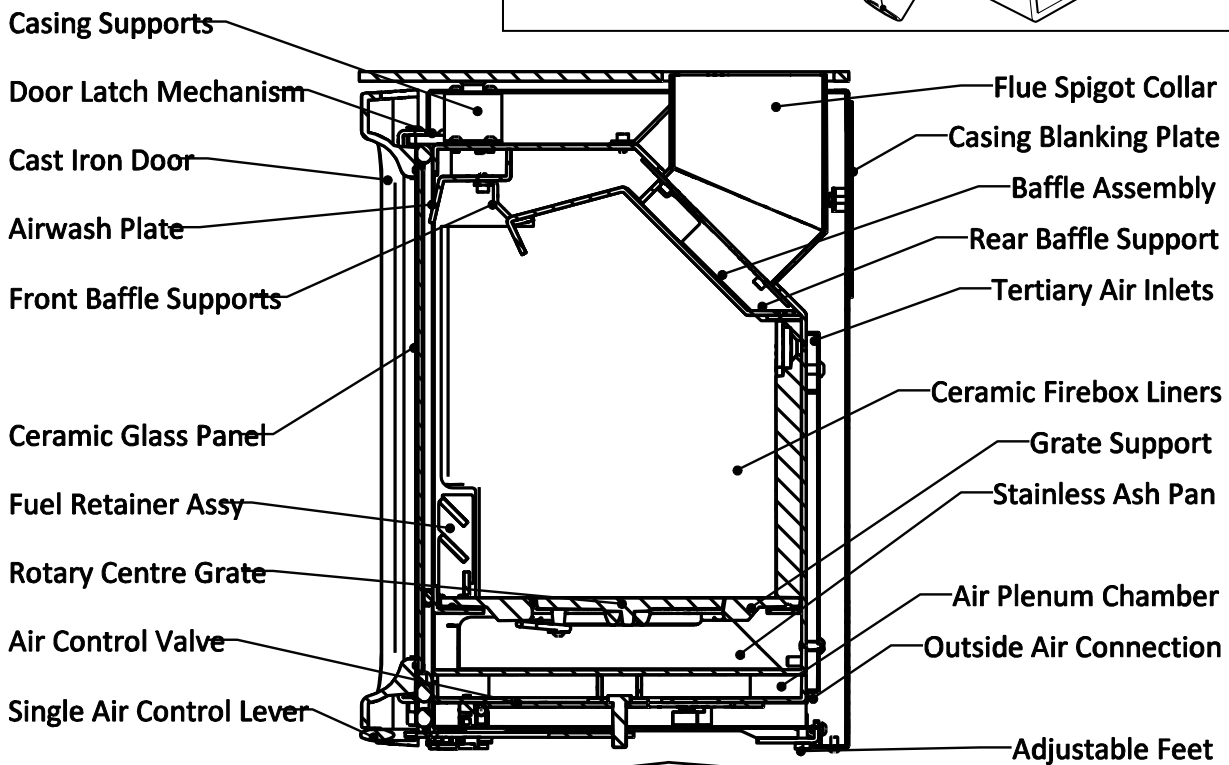
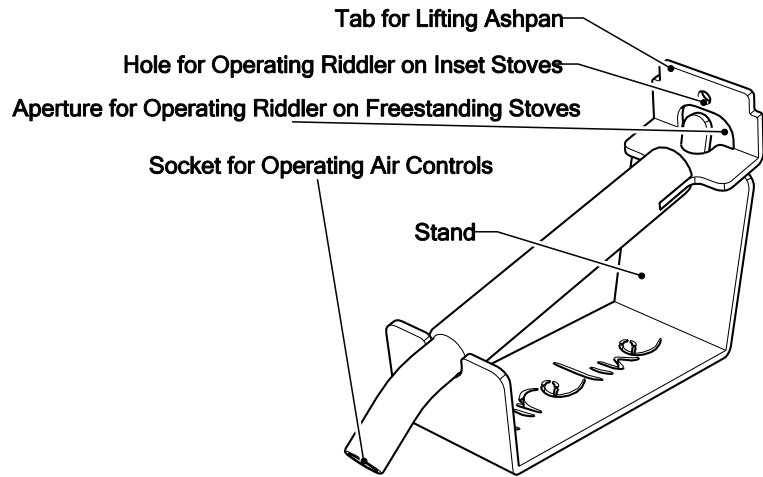
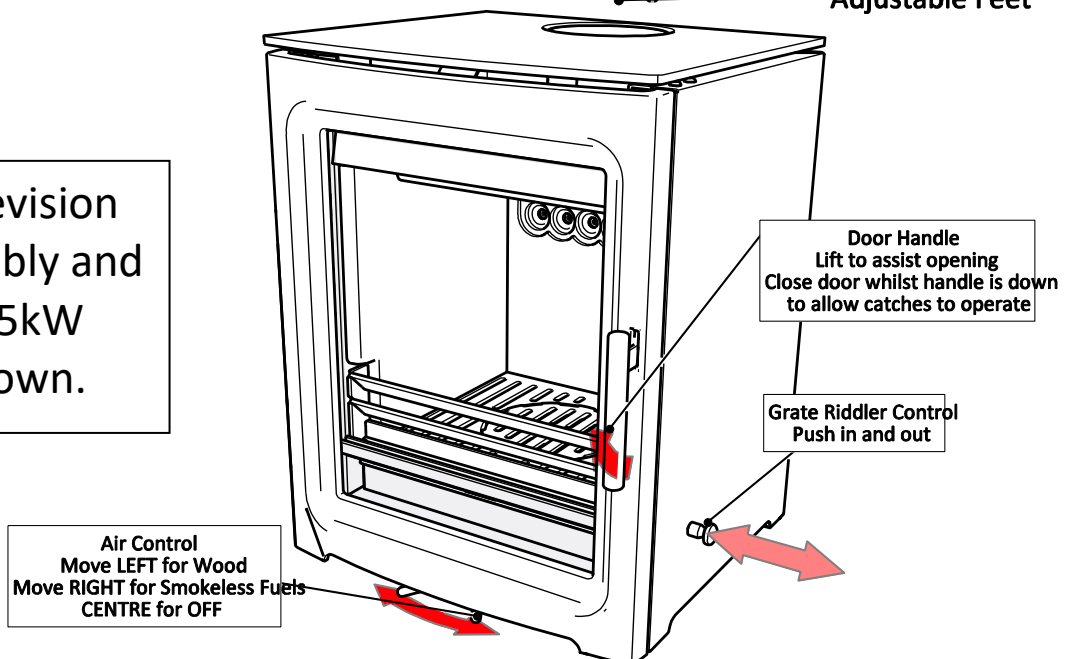

Fig 2 – Purevision Stove Assembly and controls. 5kW model shown.



3.0 Preparation of Stove for Installation.

Your stove comes fully assembled, checked and packed in a protective plywood crate. Carefully remove the straps and lift off the top and upper crate. Remove any plastic packaging, open the door and remove all the contents. See List of Components section (above) and check contents carefully.

****IMPORTANT HANDLING WARNING!****

NEVER TIP OR ROCK THE STOVE FORWARDS DURING HANDLING AS IT MAY DAMAGE THE AIR CONTROL LEVER!

- 3.1. Remove the top plate by lifting it off - noting the adjustment screws for levelling after installation. **NOTE: The top plate MUST be re-fitted before connecting the flue pipe to the vertical spigot because the flue pipe passes through the top plate!**
- 3.2. Remove the stove door if required for easier handling of the unit. Open to about 30 degrees and lift upwards to disengage the hinge pins.
- 3.3. Remove the interior components of the stove using the following procedure. SEE ALSO MAINTENANCE GUIDE section for diagrams where required.
 - 3.3.1. Remove the baffle plate by supporting the plate with both hands and lifting the front edge towards you and sliding the back edge off the back support and down slightly into the firebox. Once the rear is lowered then the front edge can also be lowered off the front baffle supports.
 - 3.3.2. Next remove the two cast ceramic firebox side liners by pulling the front edges inwards towards the centre of the firebox and sliding away from the 45 degree mitre joint with the back liner at the rear corners. Take great care not to chip or damage the surfaces of these ceramic components - support the rear liner so that it cannot fall over and break!
 - 3.3.3. Now remove the firebox rear liner. Handle and store these ceramic liners very carefully to one side where they will not get broken.
 - 3.3.4. Remove the fuel retainer assembly noting its location slots at the front firebox corners.
- 3.4. Rock the stove to the left and right side in turn and set the adjustable feet of the stove to approximately their MAXIMUM position. They can be re-adjusted lower later if required. **NOTE: DO NOT rock the stove forward as it may damage the air control lever!**
- 3.5. The flue spigot collar may now be configured for horizontal connection if required.
 - 3.5.1. Remove the 4 x M6 cap screws in the upper rear firebox and remove the spigot. If necessary remove screws from the casing to assist if required.
 - 3.5.2. The casing blanking plate can now be taken out by removing its 2 x securing nuts and securing bar and lifting off.
 - 3.5.3. Finally the spigot may then be rotated by 180 degrees and re-fitted either using the gasket provided or re-sealing with fire cement as required.
 - 3.5.4. The casing blanking plate can now be used to cover the hole in the top plate.
- 3.6. Lift the stove into its final position using an assistant to help.

- 3.7. Fit the top plate back onto the stove before fitting the top flue connection.
- 3.8. Make the connection to the flue, chimney or liner using appropriate rigid flue pipe or adaptor, making sure to seal all joints carefully.
- 3.9. Now proceed to complete the installation of the stove according to these instructions, Building Regulations and current installation standards or HETAS advice.
- 3.10. The internal parts of the stove can be re-assembled as the reverse of the previous removal instructions.

4.0 Important Safety Information

4.1. WARNINGS AND IMPORTANT SAFETY INFORMATION

4.1.1. READ THESE INSTRUCTIONS CAREFULLY BEFORE INSTALLATION!

These instructions cover the basic principles to ensure satisfactory installation of the stove, although detail may need slight modification to suit particular local site conditions. In all cases the installation must comply with current local regulations including Building Regulations, Local Authority Byelaws and other specifications or regulations including UK or EU standards referred to as they affect the installation of the stove. Approved Document J is particularly important for England and Wales and can be downloaded for no cost at:

<http://www.planningportal.gov.uk/england/professionals/en/400000000503.htm>

! Also of importance are Approved Documents (A.D.) L1 A and B conservation of fuel and power. The Domestic Heating Compliance Guide will also be found useful.

In addition to these instructions the requirements of BS 8303 and BS EN 15287 must be fulfilled. The installation of a stove is a notifiable building works as defined in the building regulations and it is a legal requirement under England and Wales Building Regulations that the installation is either carried out under Local Authority Building Control approval or is installed by a Competent Person registered with a Government approved Competent Persons Scheme. HETAS or OFTEC operate schemes and a listing of their Registered Competent Persons can be found on their websites at www.hetas.co.uk or <https://www.oftec.org/consumers/find-an-oftec-registered-technician> .

4.1.2. Important Chimney Warning

This stove must not be installed into a shared chimney that serves any other heating appliance.

4.1.3. Extractor Fan Warning

There must not be an extractor fan fitted in the same room as the stove as this can cause the stove to emit fumes into the room. If unavoidable the appliance must be checked with Approved Document (A.D.) 1.21 and necessary action taken.

4.1.4. Cleaning and Chimney Sweeping

The appliance, flue & chimney must be cleaned and checked internally and externally regularly in use and especially after a period of disuse (e.g. after summer). Lift down the baffle at least weekly to check for build up of soot or debris on the top from the flue pipe. Remove the baffle and check the flue spigot and connector is

fully clear at regular intervals. The chimney and flue connector must be swept at least annually, more often when used with sooty fuels or damp wood. The chimney or flue can usually be swept through the appliance. A wire centred sweeps brush with guide wheel is recommended. Any loose, broken or leaking joints or flue ways **MUST** be repaired immediately.

4.1.5. Fuels

Only use recommended fuels which are seasoned (or kiln dried) wood logs or smokeless briquetted fuels. The appliance can be damaged by burning petroleum coke, liquid fuels or general rubbish and this will invalidate your warranty and risk your personal safety. **The appliance must not be used as a rubbish incinerator.**

4.1.6. Maintenance

Annual checking and servicing of the appliance and flue by a competent engineer is recommended.

4.1.7. Ventilation

Adequate ventilation is **ESSENTIAL** for the safe and efficient operation of any solid fuel or wood burning appliance. Ventilation **MUST** be provided where required by the stove output or flue under-performance. Keep all ventilation clear and free of blockage, including the direct outside air connection where used. See **VENTILATION** in **INSTALLATION INFORMATION** section.

4.2. Health And Safety Precautions

Special care must be taken when installing this stove to meet all requirements of the Health & Safety at Work act.

4.2.1. Handling

Adequate facilities must be available for unloading and site handling. Stoves are very heavily built so always ask for assistance when lifting and siting them. See Technical Data for weights.

4.2.2. Fire Cement

Some types of fire cement are caustic and should not be allowed to come into contact with the skin. In case of skin contact, wash immediately with plenty of water.

4.2.3. Asbestos

This stove contains no asbestos. If there is a possibility of disturbing any asbestos in the course of installation then please seek specialist guidance and use appropriate protective equipment.

4.2.4. Metal Parts

When installing or servicing this stove, proper care should be taken to avoid the possibility of personal injury. Injury may be caused by component weight, sharp parts or trapping for example and these risks should be identified and minimised.

5.0 Installation Information

5.1. Chimney/flue

The chimney height and the position of the chimney terminal should conform to Building Regulations. **Minimum chimney height is 4.5m and the recommended minimum diameter is 150mm wherever possible for safety margin and performance.** The

chimney must be swept before connection to the stove. Check that the chimney is in good condition, dry and free from cracks and obstructions. The diameter of the flue should not be less than 125mm (spigot diameter) at any point and not greater than 200mm. If any of these requirements are not met, the chimney should be lined by a suitable method. When using a liner a 6" diameter is strongly recommended where it can be used but failing that a 5" flexible flue liner is permitted be used for Purevision stoves providing that the users only burns smokeless fuel or seasoned wood logs with the air limiter fitted in in full accordance with the wood burning instructions.

Where the chimney is believed to have previously served an open fire installation, it is possible that the higher flue gas temperature from the stove may loosen deposits that were previously firmly adhered, with the consequent risk of flue blockage. It is therefore recommended that the chimney be swept a second time within a month of regular use after installation.

If you have any doubts about the suitability of your chimney, consult your local dealer/stockist or chimney specialist. If there is no existing chimney then either a solid fuel compatible prefabricated block chimney or a twin-walled insulated stainless steel flue to BS 4543 can be used. These chimneys must be fitted in accordance with the manufacturer's instructions and Building Regulations.

5.2. Ventilation

Document J of the Building Regulations states that purpose provided ventilation is not required in England and Wales unless the appliance nominal rated output is greater than 5kW. Over 5kW 5.5 cm² of ventilation (550mm²) is required for every kW output above 5. For example 6.5 kW requires 8.25 cm² and 8 kW needs 16.5cm². In any case, if difficulty in starting the fire or any excessive fuming is experienced, ventilation must be put in place as required to eliminate these flue problems. If a flue draught stabiliser is fitted then extra ventilation is required. See Document J of the Building Regulations for detailed guidance especially in new build properties. A specifically designed direct outside air connection may be used with these stoves to provide appropriate levels of ventilation (significantly in excess of the above requirements) directly to the stove and chimney as follows. NOTE: in order to register the installation with HETAS as of early 2016 certain extra evaluation and checking is required if using an outside air connection. If the direct air kit is used and no ADJ vent is installed then a direct registration with Building Control may also be possible.

5.3. Direct Outside Air Connection

Purevision stoves are supplied with the facility of using a dedicated 100mm diameter direct connection duct through a suitable route to the outside air. It can either be connected to the rear or the underside of the stove and should be fitted at the time of stove installation. Only the approved kit for Purevision stoves should be used. This is designed to supply all the necessary air for safe combustion and operation of the stove - ***providing there is no depressurisation of the property by mechanical or other types of ventilation, the flue, chimney and ventilation duct are working correctly, and properly maintained clear of obstructions or leaks etc.*** The kit supplies all the primary, secondary and tertiary air to the stove and also provides room ventilation in excess of the Document J Building Regulations during re-fuelling via the air connection unit under the stove and so subject to no depressurisation (as above) may be used where mechanical ventilation and heat recovery (MVHR) units are used. Some additional instructions for installation are provided with the dedicated kit supplied. NOTE: in order to register the installation with HETAS certain extra evaluation and checking is required if using an

outside air connection. If the direct air kit is used and no ADJ vent is installed then a direct registration with Building Control may also be possible.

5.4. Flue Draught

A flue draught at the flue collar of minimum 2.2mm to a maximum 3.5mm water gauge (22 to 35 Pascals) is required for satisfactory appliance performance. This relates to 12-25 Pascals at the tapping on EN13240/13229 test rigs. The flue draught should be checked under fire at high output and, if it exceeds the recommended maximum, a draught stabiliser must be fitted so that the rate of burning can be controlled to prevent over-firing.

5.5. Connection to the Chimney

This appliance is **not** suitable for use in a shared flue.

Whilst 150mm diameter flue or liner is recommended wherever possible, a suitable 5" flexible flue liner is permitted be used on Purevision stoves providing that they only burn smokeless fuel or seasoned wood logs with the air limiter fitted in in full accordance with the wood burning instructions.

An existing fireplace opening can be bricked up or sealed with a register plate. A short length of suitable quality rigid flue pipe of a minimum 125mm internal diameter may then be used to connect the stove to the chimney. A maximum of 150mm horizontal flue pipe can be used. This flue pipe should conform to Building Regulations. If the connecting pipe enters the vertical flue way at any other angle except vertically, ensure that the pipe end is no closer (along the direction of the pipe) than 76mm to the side or rear chimney walls. Ideally, the old fireplace should be filled in so that there is a smooth streamlined entry into the flue way. It is essential that all connections between the stove and chimney-flue are sealed and made airtight with sealing rope, clamping rings and/or fire cement or heat resisting cement where required.

Both the chimney and flue pipe must be accessible for cleaning and if ANY parts of the chimney cannot be reached through the stove (with baffle removed), a soot door must be fitted in a suitable position to enable this to be done.

5.6. Material Clearance Dimensions

5.6.1. Safety Distances from Combustible Surfaces:

FREESTANDING MODELS

Model	Side	Rear <i>Single Wall Flue</i>	Rear <i>Twin Wall Flue</i>	Corner <i>Twin Wall Flue (from rear corners)</i>
Purevision 5kW Slimline	200mm	375mm (3 x diameter)	300mm	100mm
Purevision 5kW	250mm	300mm	100mm	Not Tested
Purevision 5kW Wide	250mm	300mm	150mm	Not Tested
PV 5kW Wide Slimline	250mm	300mm	150mm	Not Tested
Purevision 8.5kW	300mm	300mm	200mm	Not Tested

In addition, it is recommended that any furniture or other combustible materials are kept at least 1300mm clear from the front of the stove.

Unless additional heat shielding is provided, use minimum 3 x diameter distance to combustible materials for single wall flue pipes.

NOTE: Combustible surfaces can be protected from radiant heat from the stove by adding non-combustible (e.g. metal or fireproof cement board/tiles etc) heat shielding between the stove and the materials with an open air gap (e.g. 8-12mm) behind it. By doing so, safe distances may be substantially reduced to 50-75mm in practice.

COMBUSTIBLE SHELVES AND BEAMS

Due to the fact that combustible shelves, timber fireplaces and beams have potentially thousands of possible configurations in conjunction with stoves outset or inserted partially or fully into chambers, it is not possible to give firm guidance on dimensions to these features. As a guideline, materials that are in 'line of sight' to the stove are more likely to overheat due to direct radiation from the stove body than materials that are not in 'line of sight' (e.g. with stove fully inside a chamber). Materials above the stove are far more likely to overheat than materials alongside or below. A guideline limiting temperature for solid timber (not surface finishes) is approximately 80-85 degrees C with a normal ambient room temperature. Temperatures of combustible materials can be substantially lowered with a simple heat shield constructed of a non-combustible material and small air gap (6-12mm for example) between the shield and combustible material.

5.6.2. Distances from NON-combustible materials:

The stove can be recessed in a suitable sized non-combustible fireplace but a permanent free air gap of at least 50mm must be left around the sides and top and at least 50mm at the back of the stove to obtain reasonable heat output and for access to the stove for removal and maintenance. A clearance of 150mm will give a better heat output

In accordance with Building regulations all non-combustible walls closer than 400mm to the stove should be at least 75mm thick. For practical reasons the back wall of the fireplace recess and the hearth should be made of non-combustible material.

5.7. Hearths:

These stoves do not require a constructional hearth beneath them as they do not cause the floor temperature to exceed 100 degrees C. Hearths must be generally level. In all instances a non-combustible superimposed hearth extending fully underneath the stove and forming an apron of at least 225mm at the front of the stove and 150mm on either side must be provided. The superimposed hearth must not be less than 12mm thick and must have a clearly defined edge (change of level) to discourage placing of any combustible materials on or partially over it. If installed at floor/hearth level without stand or log store, it is possible that floor coverings up to 400mm in front of the stove can be affected by heat radiated from the stove window. Ensure that these materials are resistant to a temperature of at least 140 degrees C, provide extended hearth material or install the appliance raised up from the floor level using stands or log stores.

The appliance shall be installed on a floor with adequate load-bearing capacity. If the existing construction does not meet this requirement, suitable measures (e.g. load distributing plate) should be provided to achieve it.

5.8. Accessories

Purevision stoves are provided with a selection of accessories including stands, log store stands, and a dedicated outside air kit. Only use genuine Purevision accessories.

5.9. Commissioning and Handover

CO Alarm: Building Regulations require that whenever a new or replacement fixed solid fuel or wood/biomass appliance is installed in a dwelling a carbon monoxide alarm must be fitted in the same room as the appliance. Further guidance is available in BS EN50292:2002 and from the alarm manufacturer's instructions. Provision of an alarm must not be considered a substitute for either installing the appliance correctly or ensuring regular servicing and maintenance of the appliance and chimney system.

Upon completion of the installation, allow a suitable period of time for any fire cement and mortar to dry out. A small fire may then be lit and checked to ensure the smoke and fumes are taken from the stove up the chimney and emitted safely to atmosphere.

Advise the customer not to run the stove at full output for at 3 - 4 days. Explain that the stoves can provide much more or less output than their rated heat outputs depending upon fuels, fuel loads used and how they are operated.

Warn the customer that using excessive air (having the air controls open too wide for too long) can over-fire and irreparably damage the stove. Damage caused by over firing is NOT covered by any warranty.

On completion of the installation and commissioning, check all parts of the appliance are correctly fitted and ensure that the operating instructions and operating tools (including gloves) for the stove are left with the customer. You must be sure to advise the customer on the correct use of the appliance with the fuels likely to be used on the stove and warn them to use only the recommended fuels for the stove.

Advise the user on what to do should smoke or fumes be emitted into the room from the stove - see **Safety Notes** section. The user should be warned that they **MUST** use a suitable fireguard in the presence of children, aged and/or infirm persons.

6.0 Technical Data, Declaration of Performance and Conformity DoP & DoC

Ecodesign for Energy-Related Products Regulations 2010 UK SI 2010 No 2617 and EU 2015/1186 implementing 2009/125/EC

Manufacturer: Fireline UK Ltd, a Division of Charlton & Jenrick Ltd.

Range Designation: Purevision freestanding stoves.

Models: Purevision 5kW, 5kW Slim, 5kW Wide, 5kW Wide Slim & 8.5kW inc Countryman. Nominal outputs of 5kW and 8.5kW.

Intended Use: Domestic heating appliances

Independently Performance & Safety tested by: Kiwa Ltd, AB No: 0558/Kiwa Cermet Italia, NB No: 0476

Constancy of Performance System: System 3: ISO9001

Model	Purevision 5kW Slimline Models inc Countryman	Purevision 5kW Models inc Countryman	Purevision 5kW Wide Models inc Countryman	Purevision 5kW Wide Slim Models inc Countryman	Purevision 8.5kW Models inc Countryman
Appliance weight (packed/unpacked) (Kg):	94/82	105/94	120/108	105/94	153/139
Approximate Output Range: (kW)	3.9-6.8	3.1 - 6.8	3.8 - 8	3.8-6.5	4.9-10
Harmonised EN European Standard (hEN):	EN13240: 2001 Amd 2: 2004	EN13240: 2001 Amd 2: 2004	EN13240: 2001 Amd 2: 2004	EN13240: 2001 Amd 2: 2004	EN13240: 2001 Amd 2: 2004
Additional Characteristics Test Standard:	DIN +	DIN +	DIN +	DIN +	DIN +
Additional Particulate Emission Test Standard:	PD6434	PD6434	PD6434	PD6434	PD6434
Performance Characteristics - Wood Fuel					
Original Test Report Number and Issue Date:	61740 09/23	60228 10/2013	60229 10/2013	60843 10/2016	60230 10/2013
Total Efficiency: (%)	79.0	80.2	82.2	77.1	76.7
Declared nominal output: (kW)	5	5	5	5	8.5
Tested nominal Output: (kW)	5.0	4.9	5.0	5.0	8.4
Tested wood re-fuelling interval: (h)	0.77	0.75	0.76	0.76	0.75
Flue gas mass flow: (g/s)	4.3	3.6	3.6	4.5	5.9
Mean CO emission (@13% O ₂): (%)(Nmg/m ³)	0.06 (795)	0.1 (1250)	0.08 (1000)	0.1 (1250)	0.1 (1250)
Mean C _n H _m emission (@13% O ₂): (Nmg/m ³)	53	96	61	69	76
Mean NO _x emission (@13% O ₂): (Nmg/m ³)	92	124	128	92	96
DIN+ particulates (@13% O ₂): (Nmg/m ³)	19	17	10	22	19
PD6434 Particulate Emissions High output: (gh ⁻¹)	4.0	2.5	3.2	2.4	3.7
PD6434 Particulate Emissions Low output: (gh ⁻¹)	1.1	1.5	1.5	1.2	1.7
Optical Density Time > 0.2 High (Mins)	0.6	1.2	0.2	0.2	0.4
Optical Density Time > 0.2 Low (Mins)	1.6	0.7	0.4	0.3	1.4
*Mean Flue Temperature: (Deg C)	286	301	274	295	363
clearSkies Level	5	5	5	4	4
Calculated Seasonal Efficiency η _s	69.0	70.2	72.2	67.1	66.7
EEL Energy Rating Category	A	A+	A+	A	A
Approximate Max Log Length: (mm)	300	300	400	400	400 - 650
Performance Characteristics - Maxibrite Briquetted Fuel					
Total Efficiency: (%)	80.9	82.6	78.2	82.5	80.0
Declared nominal output: (kW)	5.0	5.0	5.0	5.0	8.5
Tested nominal output: (kW)	5.2	5.3	5.0	5.0	8.7
Tested re-fuelling interval: (h)	1.02	1.03	1.04	1.09	1.02
Flue gas mass flow: (g/s)	3.7	3.3	3.4	3.0	6.1
Mean CO emission (@13% O ₂): (%)(Nmg/m ³)	0.06 (745)	0.04 (500)	0.04 (500)	0.06 (625)	0.03 (375)
Mean C _n H _m emission (@13% O ₂): (Nmg/m ³)	26	8	5	12	6
Mean NO _x emission (@13% O ₂): (Nmg/m ³)	153	87	115	103	110
DIN+ particulates (@13% O ₂): (Nmg/m ³)	26	11	8	14	15
Mean Flue Temperature: (Deg C)	285	318	279	265	335
Safety Distances from Combustible materials					
Side Wall: (mm)	200	250	250	250	300
Rear Wall: (mm)	300/100	300/100	300/150	300/150	300/200

Signed:

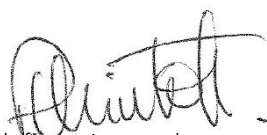

Peter Mintoft
Director
September 2023

Note: This document also forms the Declaration of Conformity (DoC) for The Ecodesign for Energy-Related Products Regulations 2010 (2010 No 2617)

NOTE: Refuelling intervals for testing are chosen according to the standards concerned for performance testing and are comparative only. They **do not** relate directly to re-fuelling intervals that can be achieved on an installed product. Re-fuelling intervals of 1-1.5h for wood and 3-4+ hours for briquetted smokeless fuels would be more usual. Under normal conditions on a low air control setting stoves should stay in overnight on suitable briquetted smokeless fuel.

7.0 Operating Instructions

7.1. Safety Notes for your guidance

7.1.1. FIRES CAN BE DANGEROUS - Always use a fireguard to BS 8423:2002 Fireguards for use with solid fuel appliances in the presence of children, the elderly or the infirm.

7.1.2. DO NOT perform modifications to the appliance as this could seriously compromise safety in operation.

7.1.3. DO NOT OVERFIRE - it is possible to fire the stove beyond its design capacity, this could damage the stove, so watch for signs of over firing - if any part of the stove starts to glow red, including baffle plate or fuel retainer, the fire is in an over fire situation and the controls should be adjusted accordingly. Never leave the stove unattended for long periods without first adjusting the controls to a reduced and safe setting - **careful air supply control should be exercised at all times.**

7.1.4. WARNING - FUME EMISSION

Properly installed and operated, this appliance will not emit fumes. Occasional fumes from de-ashing and refuelling may occur which is not normally of serious concern.

However, persistent fume emission is potentially dangerous and must not be tolerated.

If fume emission does persist, then the following immediate action should be taken: -

1. Open doors and windows to ventilate room
2. Let the fire out, or remove and safely dispose of fuel from the appliance.
3. Check for flue chimney blockage and clean if required.
4. Do not attempt to re-light the fire until the cause has been identified and corrected.

If necessary, seek professional advice from chimney or stove specialists.

Important! - Do not fit an extractor fan in the same room as this appliance.

7.1.5. IN THE EVENT OF A CHIMNEY FIRE

- Raise the alarm to let others in the house know.
- Call the Fire Service
- Reduce the appliance burning rate by closing all air controls fully.
- Move furniture and rugs away from the fireplace and remove any nearby ornaments.
- Place a fireguard or spark guard in front of the stove.
- Feel the chimneybreast for sign of excessive heat.
- Do not relight the fire until the chimney and flue ways have been examined by a professional.

If the wall is becoming hot, move the furniture away. Ensure that the Fire Service can gain access to your roof space in order to check this area for signs of fire spread.

7.1.6. CO ALARMS

Your installer should have fitted a CO alarm in the same room as the appliance. If the alarm sounds unexpectedly, follow the instructions given under "Warning Note" below.

WARNING If the CO Alarm sounds unexpectedly:-

1. Open Doors and windows to ventilate the room and then leave the premises.
2. Let the fire go out.

7.2 Warnings:

This appliance is **not** designed for open operation and therefore should **not** be operated with the doors open.

This stove is designed to burn wood and smokeless fuels cleanly with high efficiency. However, for this product to work properly it must be used correctly. If used correctly this stove will burn with the very useful feature of clean glass.

It is **essential** that the stove has an adequate air supply for combustion and ventilation. DO NOT block any ventilators provided. The primary, secondary and tertiary air inlets must be kept clear of obstruction.

Warning! This appliance will be very **hot** when in operation and due care should be taken when operating the controls. A tool and pair of quality leather gloves are provided to assist safe operation.

Do not use an aerosol spray on or near the stove when it is alight.

7.3 The Clean Air Act 1993 and Smoke Control Areas

Under the Clean Air Act local authorities may declare the whole or part of the district of the authority to be a smoke control area. It is an offence to emit smoke from a chimney of a building, from a furnace or from any fixed boiler if located in a designated smoke control area. It is also an offence to acquire an "unauthorised fuel" for use within a smoke control area unless it is used in an "exempt" appliance ("exempted" from the controls which generally apply in the smoke control area).

In England appliances are exempted by publication on a list by the Secretary of State in accordance with changes made to sections 20 and 21 of the Clean Air Act 1993 by section 15 of the Deregulation Act 2015. Similarly in Scotland appliances are exempted by publication on a list by Scottish Ministers under section 50 of the Regulatory Reform (Scotland) Act 2014.

In Wales and Northern Ireland these are authorised by regulations made by Welsh Ministers and by the Department of the Environment respectively.

The Purevision PV5 5Kw, Purevision PV5 Countryman 5kW, Purevision PV5W 5kw Wide, Purevision PV5W Countryman 5kW Wide, Purevision PV5WS 5kW Wide Slimline, Purevision PV5WS Countryman 5kW Wide Slimline and Purevision PV85 8.5kW have been recommended as suitable for use in smoke control areas when burning wood logs. This is conditional upon fitting the supplied secondary air control limiters and following the wood burning instructions precisely. Suitable Authorised fuels can also be used in the appliances in Smoke Control Areas (see Authorised fuel list <https://smokecontrol.defra.gov.uk/fuels.php>)

Further information on the requirements of the Clean Air Act can be found here: <http://smokecontrol.defra.gov.uk/>. Your local authority is responsible for implementing the Clean Air Act 1993 including designation and supervision of smoke control areas and you can contact them for details of Clean Air Act requirements.

7.4 Air Controls

**Keep air controls and inlets/outlets clean and free from ash or debris at all times.
Keep direct outside air inlet grille (if fitted) clean and clear at all times.**

Do not leave air control fully open unless monitoring the fire as over firing damage can result which is not covered by any warranty.

7.4.1 **Single Air Control Operation**

Primary (under grate), secondary (air wash) and tertiary air is automatically controlled by the single control lever at the bottom, underneath the stove door. The centre position is the OFF position and closes off combustion air to the firebox. The off position should only be used if absolutely necessary for very slow burning and when burning wood will cause the glass to become blackened, the chimney to gradually become tarred and smoke to be emitted from the stove.

Wood burning: Move the lever fully to the left for maximum air to start or revive a wood fire. Returning the lever towards the centre position will reduce the air supply progressively to reduce the burn rate. The nominal burn rate is usually achieved when the stove is fully warmed up (2-3 loads of logs) and burning dry hardwood logs by having the lever very approximately 18-20mm (1-2 clicks) from the centre position. This is only a rough guide as flue and fuel conditions will vary the required position. The fire will automatically be supplied with the correct mix of secondary and tertiary air for complete combustion. The maximum position conveniently provides a boost of primary air as well to get new fuel burning quickly in order to minimise smoke. Do not leave on maximum setting unless monitoring the fire to ensure over firing damage does not occur.

Smokeless/Coal fuel burning: Move the air control lever fully to the right side for starting or reviving a coal fire. Returning the lever towards the centre position will reduce the air supply progressively to reduce the burn rate. The fire will be supplied with the correct amount of primary air for combustion of smokeless briquetted fuels and a small amount of secondary/tertiary air for completing combustion. Do not leave on maximum setting unless monitoring the fire to ensure over firing damage does not occur

7.4.2 **Air Wash**

All Fireline stoves are provided with a sophisticated "air wash" system to assist in keeping the fire as visible as possible and reducing cleaning intervals. This secondary air supply to the stove is controlled through the main single air control. The Clean Air Act air restrictor bracket will deliberately prevent full closure of this control on the Wood side of operation. On the Coal side of the lever's operation the amount of air wash air is greatly minimised to ensure good efficiency and so the glass will not remain fully clear indefinitely and will require cleaning with stove glass cleaner or ceramic hob cleaner from time to time.

7.4.3 **Tertiary Air**

This appliance is also fitted with a patented tertiary air combustion system that burns otherwise uncombusted gasses in the products of combustion thereby improving efficiency, increasing heat output and decreasing unwanted atmospheric emissions. The Tertiary air supply to the stove is controlled automatically by the draught in the flue and firebox and the single air control. At certain stages of burning you will notice "jets" of swirling flame emerging near the air holes to the rear of the firebox. For maximum efficiency on coal fuels the amount of tertiary air is greatly reduced.

7.4.4 **Multifuel Grate**

Your stove is fitted with a multifuel grate, which can be shaken from the right side of the stove by pulling and pushing the knob as required. The slot in the operating multi tool can be used to operate the knob or use the gloves supplied. The grate is a strong set of cast iron bars with suitable air slots that assist the burning of most fuels. When burning coal type fuels it is important to de-ash regularly to ensure that the primary airflow is not impeded. An excessive build-up of ash *when burning coal* can damage the cast iron grate. A build up of wood ash when burning wood will not harm the grate and indeed wood burns better on a bed of ash but excessive wood ash build up is not recommended.

7.4.5 Ashpan

It is essential that you empty the ash pan regularly when burning coal type fuels. Use the flat end of tool to lift the ash pan out of the stove. DO NOT allow coal ash to build up underneath the bed as this may cause damage to the grate.

7.5 Cleaning

Glass: Despite the advanced air wash system provided, the glass will still need cleaning from time to time depending on the fuel quality and burning rates used. Never clean glass when the stove is hot. Always use stove glass cleaner or ceramic hob cleaner, which is available from your stove retailer or supermarket. As an alternative, use a wet cloth with some of the wood ash if burning wood but be very careful to use very clean ash so as not to scratch the glass. DO NOT use coal ash to clean the glass.

Outer body: The outer body simply needs to be dusted or wiped with a clean damp cloth from time to time. DO NOT use any kind of furniture polish or cleaning agent other than your stove suppliers recommended paint.

Inner firebox: Brush the inside of the firebox clean from time to time to check the integrity of the plates and liners etc. See Maintenance Guide section for instructions on how to remove parts of the stove. It is not normally necessary to re-paint inside the firebox due to the high temperatures that mean that the paint does not have much effect before being burnt off. Steel and high quality cast ceramic liners are very resilient firebox materials and will give reliable service without major cleaning or work on the firebox. The ceramic liner boards are very durable but may require replacement occasionally depending upon fuels and the type of usage experienced. Firebox linings are not covered by warranty, as they are a wearing consumable part.

Baffle: It is essential to check the top of the baffle for build up of soot and ash regularly when in use and after a long period of disuse - e.g. summer. From time to time remove the baffle if necessary to ensure that the flue way entrance is clear. Lift the front edge of the baffle upwards and forwards to slide the rear edge off its support. Lower the rear edge and then slide the baffle off its front supports to leave it free for removal. See maintenance section for further details.

Air Supply: It is essential to check the air supply grille on the outside of the property if the direct outside air connection is installed. Regularly brush or vacuum out any debris, cobwebs or similar materials to ensure that the air supply is not restricted. Ensure the air intake chamber visible underneath the ash pit section with the stove door open is kept free of excessive ash or debris.

7.6 Fuels

The appliance is fitted with a versatile multifuel grate and the appliance has been tested and approved burning dry, well-seasoned logs or briquetted Maxibrite smokeless fuel. These are the recommended fuels. For other fuels please contact the manufacturer for advice.

Note: Warning!- Petroleum coke fuels or household waste must not be burnt on this appliance.

Should any difficulties arise over fuel quality or suitability, consult your local approved fuel merchant.

7.7 Important Information for Wood Burning

With a full load of wood and burning near nominal output the stove will need to be refuelled approximately every 1-1.5 hours. One or two large logs will burn longer than a number of smaller ones. Wood can usually be stacked higher in the stove than solid mineral fuel but care must be taken that logs do not touch the baffle or the glass panel.

Do not stack logs above the level of the tertiary air inlet profiling in the rear ceramic firebox liners at the back of the stove.

Always make sure that flames are visible above the wood after re-fuelling for cleanest burning. **Burning without flames above the fuel will create unnecessary smoke. After re-fuelling open the single air control fully to the Wood (left) side for 3 minutes or until the logs are fully blackened to achieve full flames above the fuel.**

Wood burns best on a bed of ash and it is therefore only necessary to remove surplus ash from the stove occasionally.

Burn only dry, well-seasoned wood, which should have been cut, split and stacked - under cover from rain - for at least 12-24 months with free air movement around the sides of the stack to enable it to dry out. Burning wet or unseasoned wood will create tar deposits in the stove and chimney and will not produce a satisfactory heat output. **Wood that is not properly dry ('dry' is considered to be less than 20% internal moisture content) uses up energy from the burn process to evaporate the water inside the wood thus creating very poor conditions for combustion.** The main cause of burning problems with wood stoves is due to excessively damp wood. Wood can appear perfectly dry on the outside but still contain 40-50% water on the inside. A moisture meter can be purchased from stove and equipment suppliers if you wish to check your wood source is correct. Split a log and check the inside as well as the outside.

7.7.1 Refuelling on to a low fire bed

If there is insufficient burning material in the firebed to light a new fuel charge, excessive smoke emission can occur. Refuelling must be carried out onto a sufficient quantity of glowing embers and ash so that the new fuel charge will ignite in a reasonable period. If there are too few embers in the fire bed, add suitable kindling to prevent excessive smoke.

7.7.2 Fuel overloading

The maximum amount of fuel specified in this manual should not be exceeded, overloading can cause excess smoke. Never load fuel above the bottom edge of the tertiary air profiling in the back ceramic firebox liner or allow them to touch the glass. All models max log diameter = approx. 150mm. Max length = 300mm for 5kW, 400mm for 5kW Wide, 400mm-650mm (taper firebox) for 8.5kW models. One log is acceptable ONLY if loading onto a hot well established fire bed.

7.7.3 Operation with door left open

Operation with the door open can cause excess smoke and spillage into the room. The appliance must not be operated with the appliance door left open.

7.7.4 Primary Air left open

Operation with the primary air controls left open: The single air lever on the Coal - right hand side - can cause excess smoke. The appliance must not be operated with air control lever open on the right side when burning wood or the door left open.



7.8 Information on Smokeless Fuel (Maxibrite) burning

Maxibrite, briquetted smokeless and coal type fuels require very different burning conditions to log burning and the single air control has been designed to allow for this. Use the control on the right side of its travel marked 'Coal' for best efficiency on these types of fuel. Maxibrite and other smokeless briquetted fuels can burn with very little primary air and stay in for many hours to be revived after an overnight burn for example.

7.9 Lighting the Stove

We recommend that you have two or three small fires before you operate your stove to its maximum heat output. This is to allow the paint to cure in steadily and to give a long service life of the paint finish. During this curing in process you may notice an unpleasant smell whilst the finishes finally cure. It is non-toxic, but for your comfort we would suggest that during this period you leave all doors and windows open.

First, open the single air control fully to the left side. Load the firebox with four fully dry small-medium logs in a crossed pattern as shown:



Next add plenty of dry kindling sticks and a firelighter ON TOP of the 4 logs as shown. A crib lattice pattern tends to work well. If using Maxibrite, place a layer of Maxibrite into the firebox on the base as well and omit the large logs but use plenty of kindling. Move the active baffle lever (if fitted) into the IGN position.



Light the firelighter(s), leaving the air control fully open and close the door. It should not be necessary to leave the door open but DO NOT leave the stove unattended if you find it necessary to leave the door ajar.



The kindling will burn and set light to the logs by radiation and breaking down to charcoal gradually and with fewer emissions than the traditional logs ontop methods. Allow the fuel to reach a steady burn and usually the initial fuel can be left to burn down to charcoal without much further attention. Build the fire up carefully by adding a couple of small well split logs or an amount of Maxibrite briquettes at a time. Do not overload the fire bed with more than two logs at a time.

Once you have a good fire bed established across the grate, further fuel can be added step by step as required. Don't be tempted to overload the fire bed with fuel all at once or close down the air controls until the fire is really well established for some time. Once the ignition period is well under way, close the active baffle operating rod (if fitted) to AUTO or CLOSED positions and gradually reduce the air control opening to establish the burning intensity you require.



7.10 Re-fuelling

When burning Maxibrite the fire will begin to die down with a significant amount of white ash showing amongst the fuel. Shake the grate using the shaker and then *gently* run a poker through the fire bed to remove most of the ash into the ashpan. Empty the ashpan if it is nearly full and then re-fuel with a good load of briquettes. The fuel load should initially be level with the top of the fuel retainer and not above the rear firebox liner tertiary air inlet profiling. Whilst approval test cycles are 1 or 2 hours, a stove burning Maxibrite may be kept in overnight easily under normal conditions.

When burning wood, the fire will die down as the fuel is consumed. When the flames disappear and the remainder is breaking down into glowing embers it is an appropriate time to consider re-fuelling. NOTE: If the flames disappear and there are still lumps of solid wood left this indicates excessive internal moisture in the wood or insufficient air supply/flue draught.

NOTE: To eliminate unwanted smoke emission, after loading new logs on to the fire, open the air wash control up fully for 3 minutes or until the logs are blackened all over to boost the fire and get flames issuing from the top of the fuel as soon as possible. When flames are well established, reduce the air wash to the running setting required. **Burning without flames above the fuel will create unnecessary smoke.** Do not load fuel above the tertiary air inlet hole profiling at the back of the firebox.

Loading 1 or 2 large sized logs weighing 1-2kg DRY will produce a good output with reasonable burn time. Small logs will burn up quicker producing a high output and more emissions for a short time, and a large log will take longer to burn and produce less output and less emissions over a given time. These appliances are approved for intermittent operation on wood (0.75 to 1.5 hour burn cycles) although longer burn times can be achieved by fully loading the firebox, getting the fuel burning well and then shutting the air control right down (see below). The fire will then need reviving by first opening the air controls and then using small pieces of wood and plenty of air to get flames issuing from the wood again. Never load fuel above the rear firebox tertiary air profiling or allow it to spill onto the glass.

7.11 Shutting Down

The stove will normally shut down by itself as the fuel is consumed so there is no need to close the air control towards the end of the burn. In order to shut down the stove for other reasons, close the single air control to the central position. If the control is left in this position, the fire will eventually go out but it will also cause the glass to blacken. If you want to revive the fire it is recommended that the air control is opened fully initially.

Warning! - The stove will remain **very hot** for a considerable time after the fire has died down or been extinguished.

7.12 Shut down for prolonged periods

If the stove is to be left unused for a prolonged period of time then it should be given a thorough clean to remove ash and unburned fuel residues. To enable a good flow of air through the appliance to reduce condensation and subsequent damage, leave the air controls open. It is important that the flue connection, any appliance baffles or throat plates and the chimney are swept prior to lighting up after a prolonged shutdown period.

7.13 User Maintenance

See also the Cleaning section above and Maintenance Guide Section below for further information.

Inspect the inside of the firebox and above the baffle plate every week during use.

Where the chimney is believed to have previously served an open fire installation, it is possible that the higher flue gas temperature from the stove may loosen deposits that were previously firmly adhered, with the consequent risk of flue blockage. It is therefore recommended that the chimney be swept a second time within a month of regular use after installation. **See chimney cleaning section in section Warnings and Important Information.** Inspect the inside of the stove and the flue ways and ensure they are 100% clear after a period of disuse (e.g summer).

Check all rope seals for completeness, wear and that there are no gaps between the ends etc. Any gaps must be eliminated and ropes must be re-adhered to their grooves with suitable rope seal cement where required. Worn or missing rope seals will affect appliance operation, control and emissions output and can lead to overheating damage.

Check all air intakes and outlets within the stove for cleanliness and remove any ash or debris build up by suitable means.

Check outside air ventilators and stove air inlets are clean and unobstructed.

Only use manufacturers recommended replacement parts on the appliance.

8.0 Active Baffle System

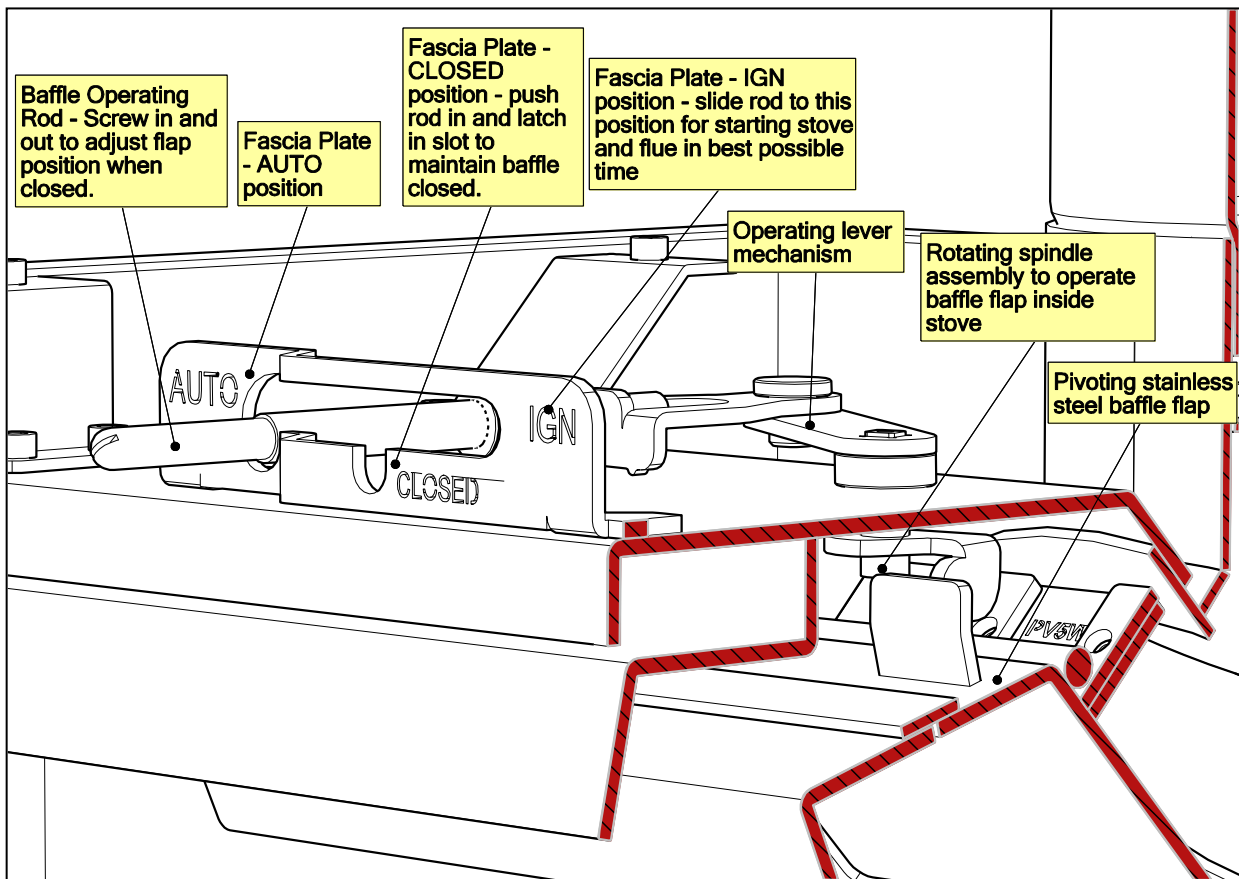

8.1 Description: The Purevision range, including the Classic versions may be fitted with an internal stainless steel active baffle assembly which fulfils a number of functions:

- a) **IGN Position:** Direct access of ignition heat into flue-way to start up cold, inactive flues in a quicker and more user-friendly way.
- b) **Auto Position:** Opening of the flue way when refuelling to enhance the fume removal capacity of the stove when the door is open.
- c) **Closed (Manual) Position:** A manual override position to retain the baffle in the permanently closed position when its assistance is not required.
- d) In the case of a low draught flue where it has been improved as far as possible by conventional means (e.g. terminal, increasing height and diameter and reducing bend severity and number where possible) the removable sections of the baffle can ease gas flow to enable safe use of the stove where otherwise it may not be possible to continue to use a wood burning stove.

8.2 Operation:

8.2.1 The baffle mode is controlled by the stainless steel rod that protrudes through the fascia panel to the top left of the stove beneath the top plate. **The rod can be operated when hot only by using the stainless steel multi-tool and stove gloves supplied with the stove.**



- A) Sliding the operating rod across to the **IGN** position allows the baffle flap to remain in the open position (regardless of the door

position) thereby allowing products of combustion straight into the flue pipe during ignition. This heats up the flue quicker to generate draught sooner and enables lower emissions to be produced during a shorter ignition phase.

- B) Sliding the operating rod to the closed position and depressing it firmly inwards and downwards into the slot until it latches fully into the **CLOSED** position allows the baffle flap to remain in the closed position permanently during all operation. This is useful where flue draw is very good even when the flue is cold.
- C) Sliding the operating rod across into the **AUTO** slot position where the rod will be depressed by the door as it closes causes the baffle flap to open when the door is open and closes it when the door is closed.



8.3 Adjustment:

Firstly check that the baffle is correctly sitting on its mountings. The degree of closing of the baffle flap is controlled by the operating rod and it must be 100% closed when the door is closed. This rod is adjustable by screwing in and out of the link on top of the firebox which is part of the operating mechanism. Screwing the rod outwards (counter-clockwise) causes the baffle to close further when the stove door is closed. Screwing the rod in (clockwise) causes the mechanism to become shorter thereby pushing the baffle less distance when the door is closed. **NOTE: The baffle must be sitting squarely on its supports for this adjustment to be correctly set so firstly remove the baffle from within the firebox and clean the rear baffle support plate.**

8.4 Removable sections:

If the installation is suffering from low flue draught and stove operation is

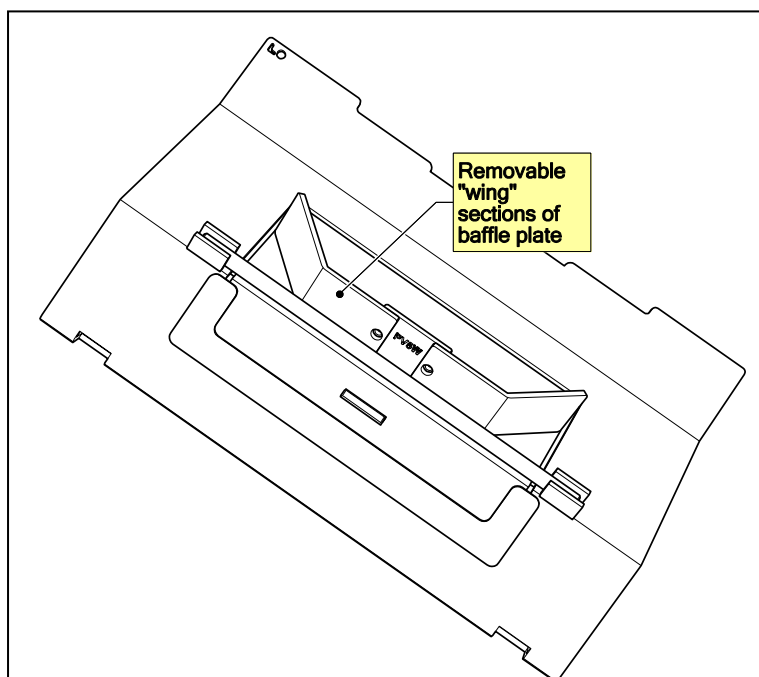

sluggish and slow despite known dry high quality fuel being used then the flue should be improved as far as possible. This means removing or at least easing any bends and having them as far up the flue system as possible; using insulated flue as far as possible within and outside of the building; increasing diameter to minimum 6" or above where possible; increasing height of the flue by means of additional terminals or flue lengths; adding anti downdraught or draught increasing cowls before making any changes to the stove. Assuming that stove operation has not improved much

once this has been carried out then as a last resort the 'wing' pieces on the

rear of the baffle may be removed to reduce restriction within the stove itself and help to compensate for the lost draught within the flue system.

9.0 Maintenance Guide

- 9.1 Removing Top Plate.** Remove the stove top plate by lifting away. Note the machined sockets and adjustable top plate supports for levelling and adjustment as required. It is not necessary to remove the top plate or door to clean or remove items from inside the firebox.

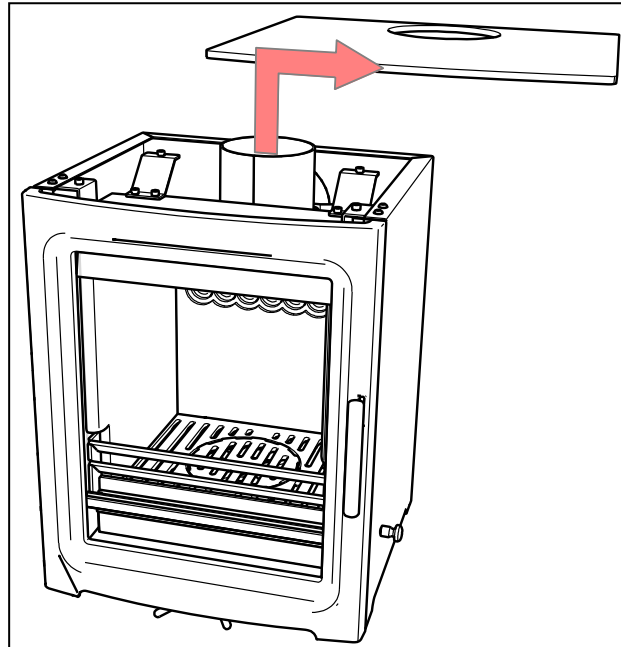

- 9.2 Removing Door.** Remove the stove door by opening to approximately 30 degrees and lifting away to disengage the hinge pins. It is not necessary to remove the door to clean or remove items from inside the firebox.

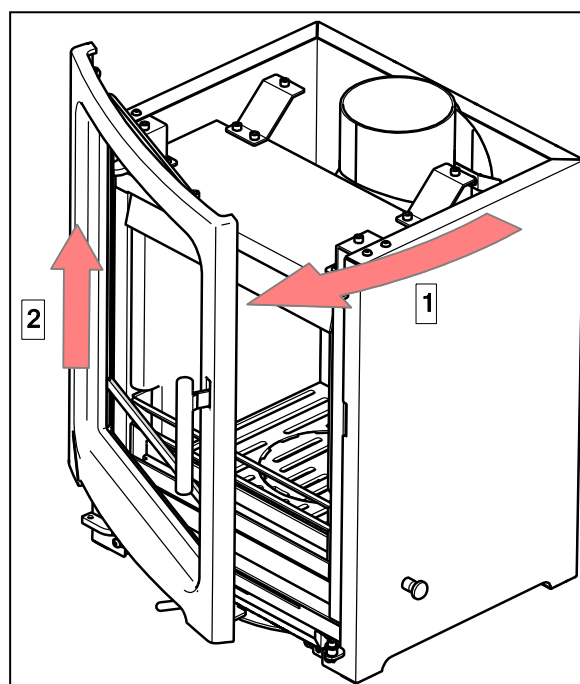

9.3 Removal of or Inspection Above Baffle Plate. 1. If retaining clips, U clips or screws are present in the front baffle supports, remove them first. First lift upwards at the front and at the same time sliding the rear forwards off the back baffle support bracket. **2.** Next lower the rear edge into the firebox and allow the front of the baffle to slide off the front baffle support brackets. **3.** Finally rotate the baffle out of the firebox

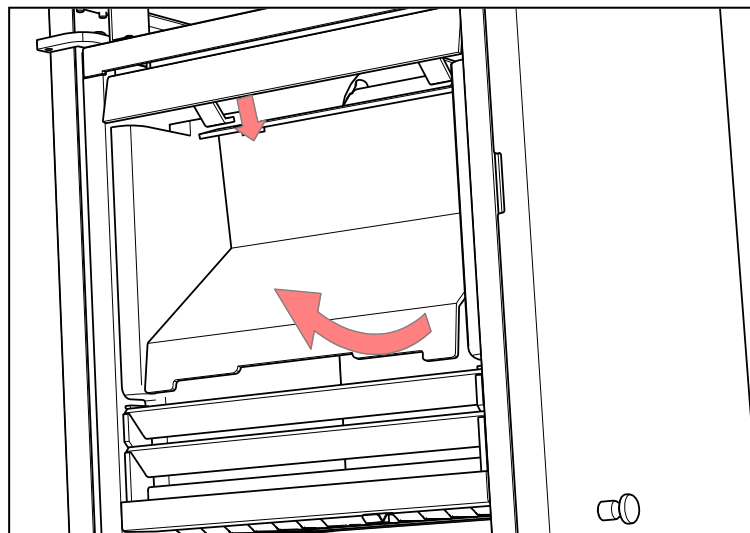
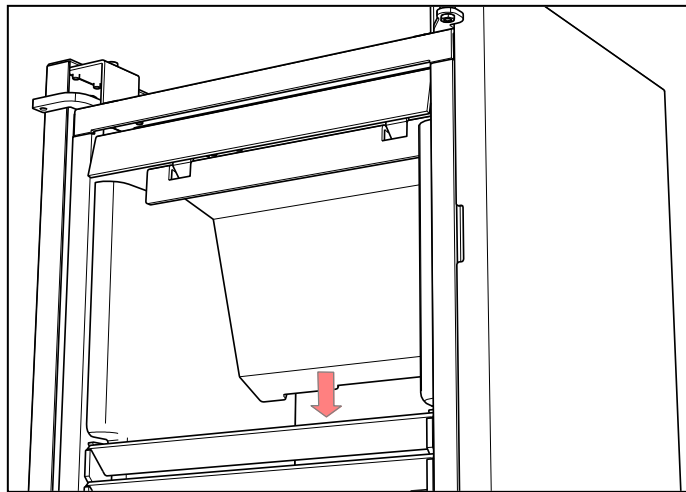
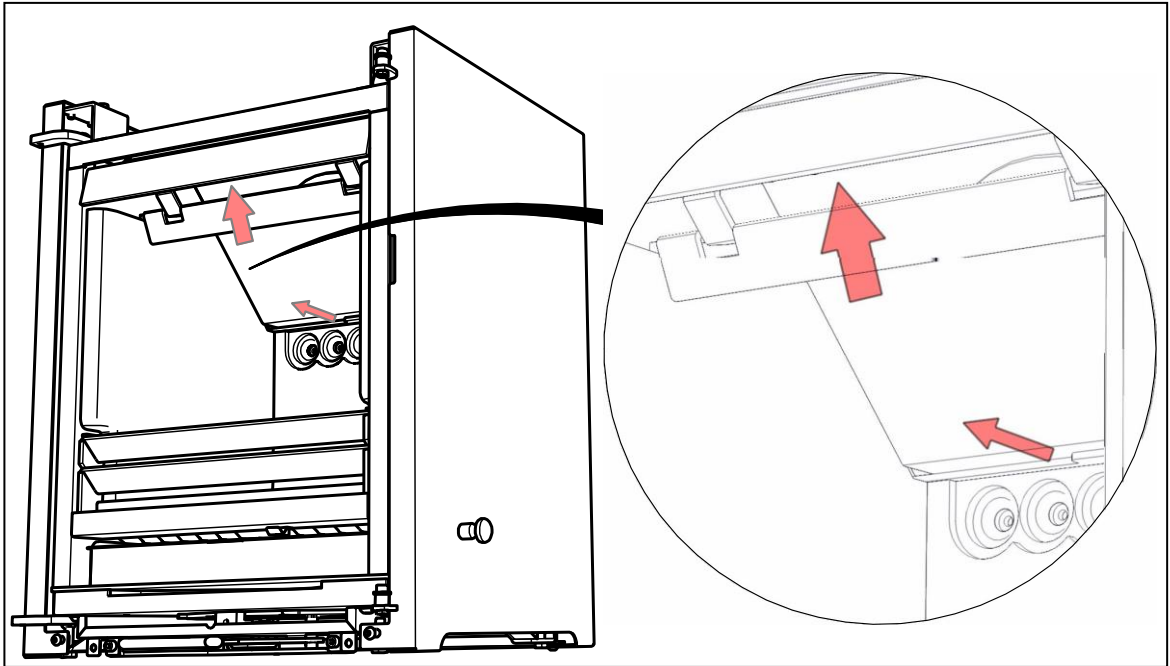

- 9.4 Removing Firebox Liners and Fuel Retainer Assembly.** 1. First slide the front edges of the left and right firebox liners inwards at the front until they disengage from the rear liner. Then tilt them slightly and remove from the firebox - **NOTE: Ensure that the rear firebox liner does not fall forwards and break!** 2. Remove the rear firebox liner being very careful not to damage the profiling at the top which is delicate. 3. Remove the fuel retainer

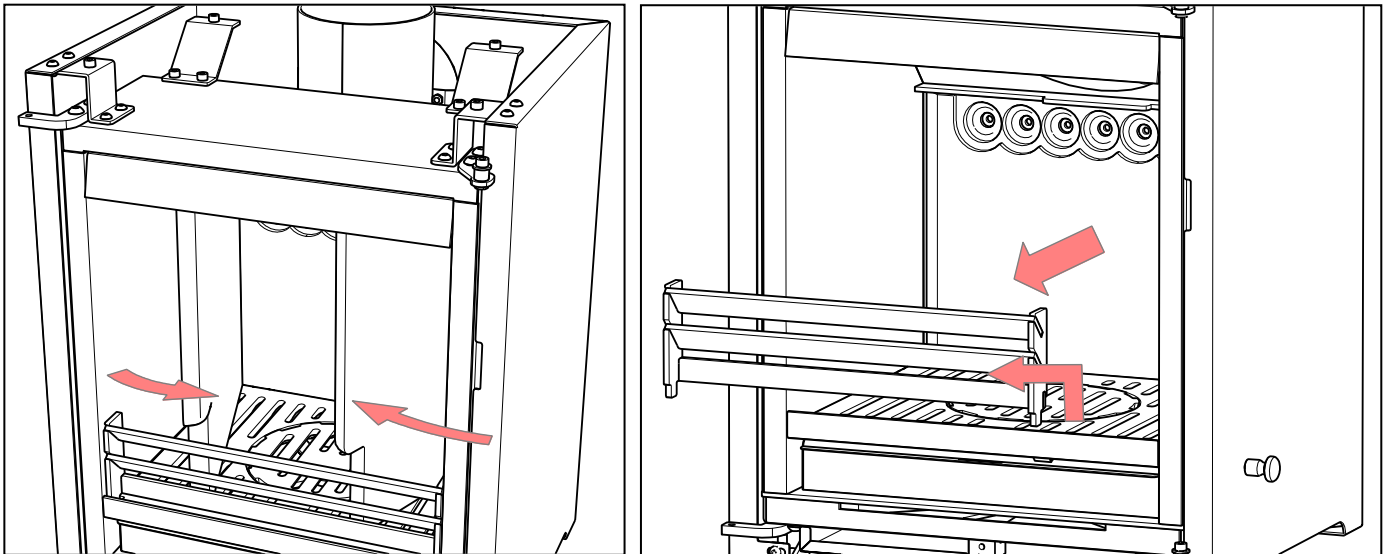

assembly by lifting up out of its slots.

- 9.5 Removing Grate components.** 1. Remove the riddling/shaker knob by unscrewing from the operating rod. 2. Unscrew the operating rod from the underside of the centre rotating grate section using a 10mm AF spanner. 3. Lift out the two grate sections and the operating rod.

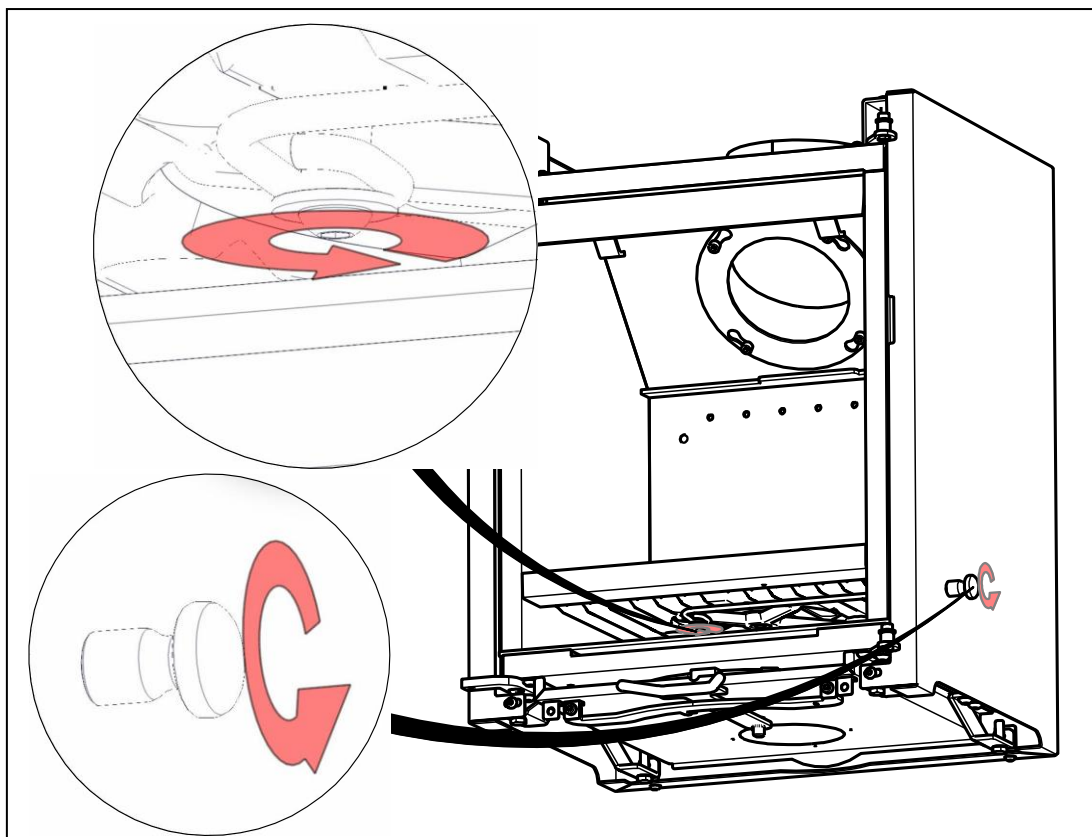

- 9.6 Removing Flue Spigot Collar.** Unscrew 4 x M6 securing screws from inside the firebox and remove spigot collar. When re-assembling either use a suitable fireproof gasket or fire cement.

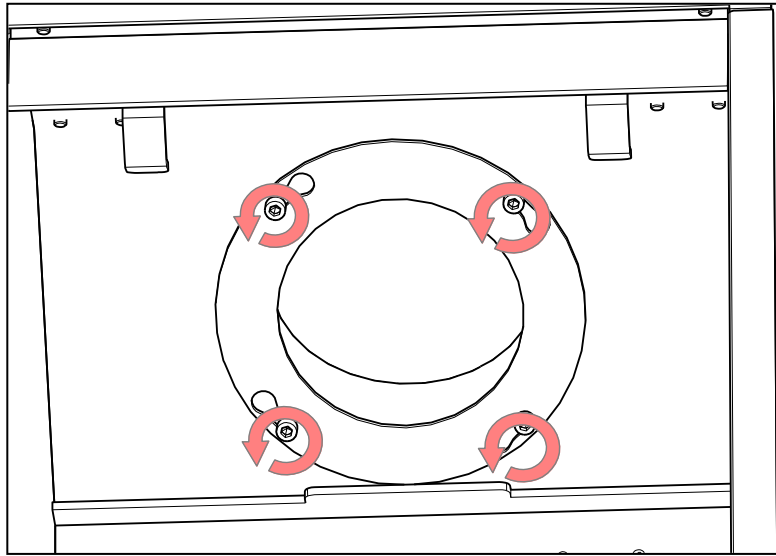

- 9.7 Removing Outer Casing.** 1. Unscrew 2 x M6 screws securing lower casing to stove legs. 2. Unscrew and remove 4 x M4 screws from both left and right upper casing brackets. Remove the brackets from the firebox itself to allow removal of the casing as easily as possible.

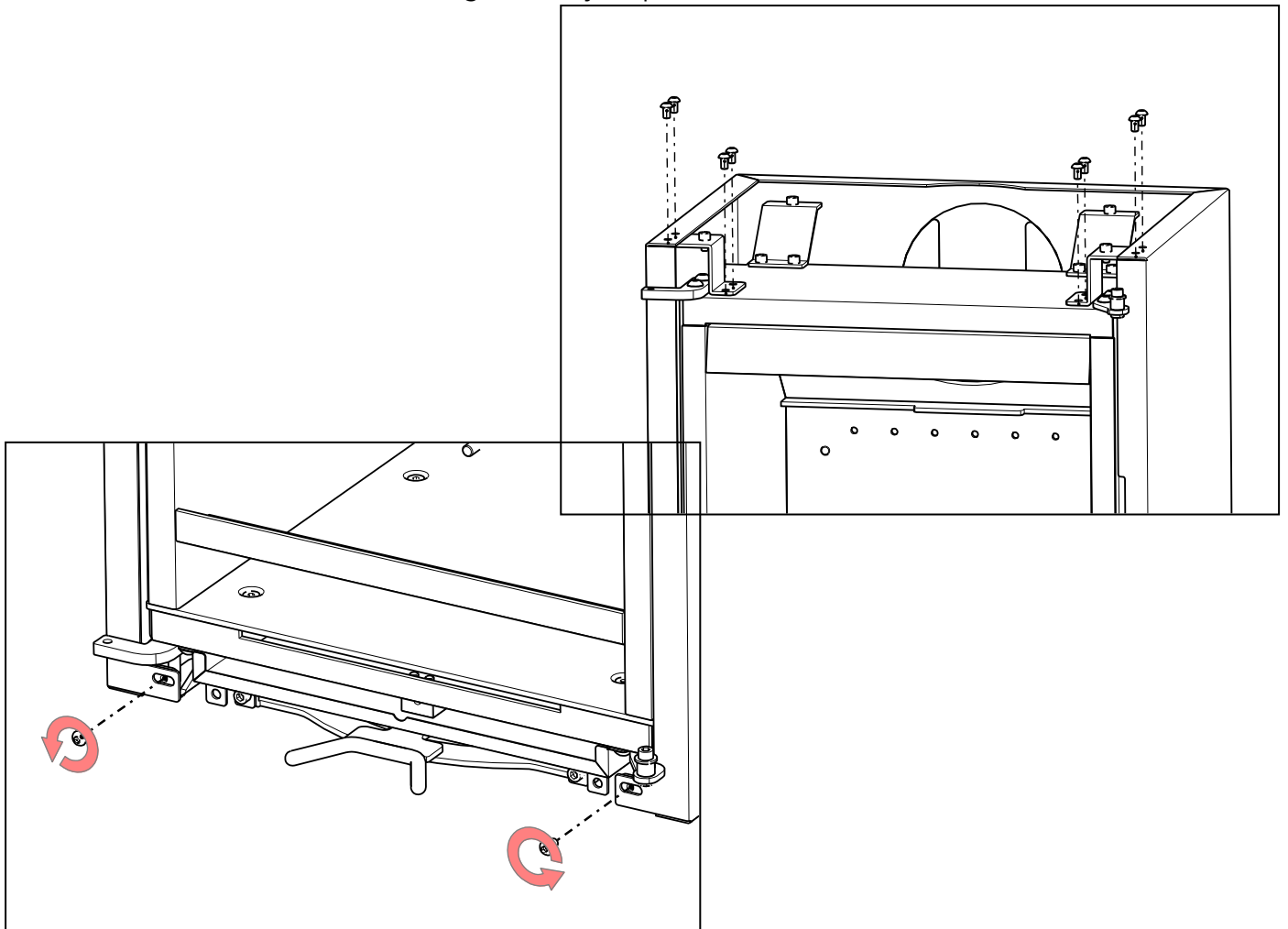

- 9.8 Door Hinge Adjustment.** Door alignment may be adjusted by slackening the door hinge securing screws and re-positioning the hinge to suit. This will adjust the horizontal alignment. For front-back alignment carefully adjust the hinges mounted on the stove body. Check the door seals with a paper strip all around after any adjustment to prove they are still sealing correctly.

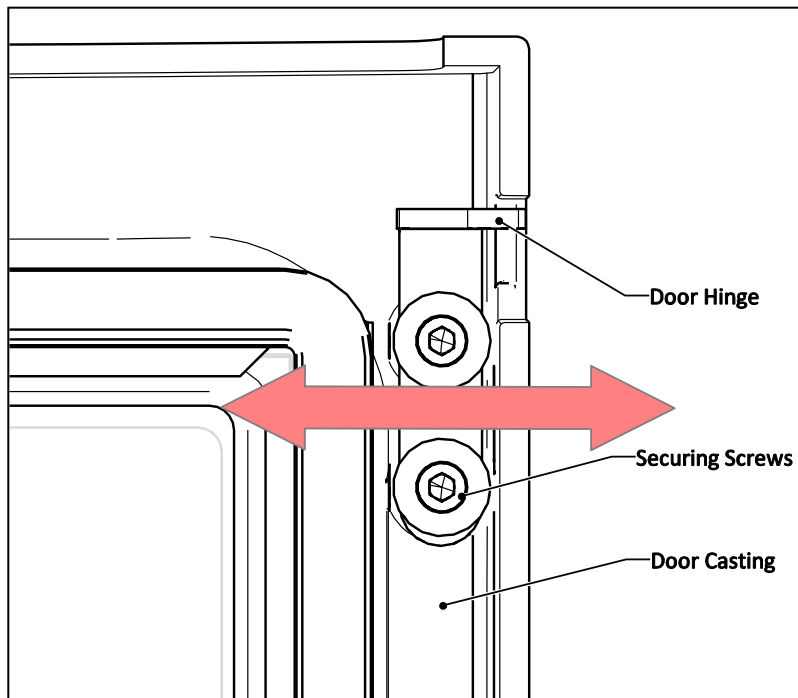

- 9.9 Smoke Control Air Limiter.** 1. If the stove is to be used to burn seasoned wood logs in a Smoke Control Zone in the UK, the Smoke Control air limiter bracket must be fitted. This bracket prevents the air control being completely closed when the stove is used to burn wood. To change to smokeless coal operation the door must be opened and the lever deliberately lifted and moved from the wood control side (left) to the coal control side (right) before lighting the fire. 2. To attach or remove the bracket, use the 2 x M6 cap screws provided as shown. **Do not lean the stove forwards when moving it to access this control bracket as it will**

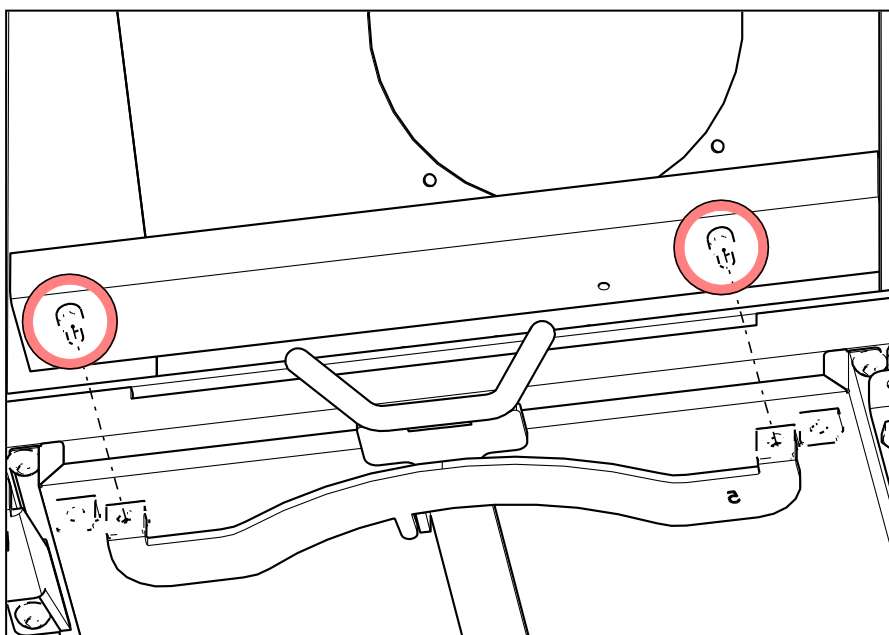

likely damage the air control lever. Either fit without moving the stove or tilt it left, right or to the rear.

9.10 Maintenance of air control valve. The main air control valve is mounted underneath the air plenum chamber which is fixed immediately beneath the ash pit. To access this for thorough cleaning and re-lubrication firstly remove the outside air box. Invert the firebox for access. To remove the outside air box remove 2 x screws from bottom of firebox and 2 x screws from rear of firebox, remove locking nuts and air control lever from spindle and lift off the outside air box. Other components can now be removed as required.

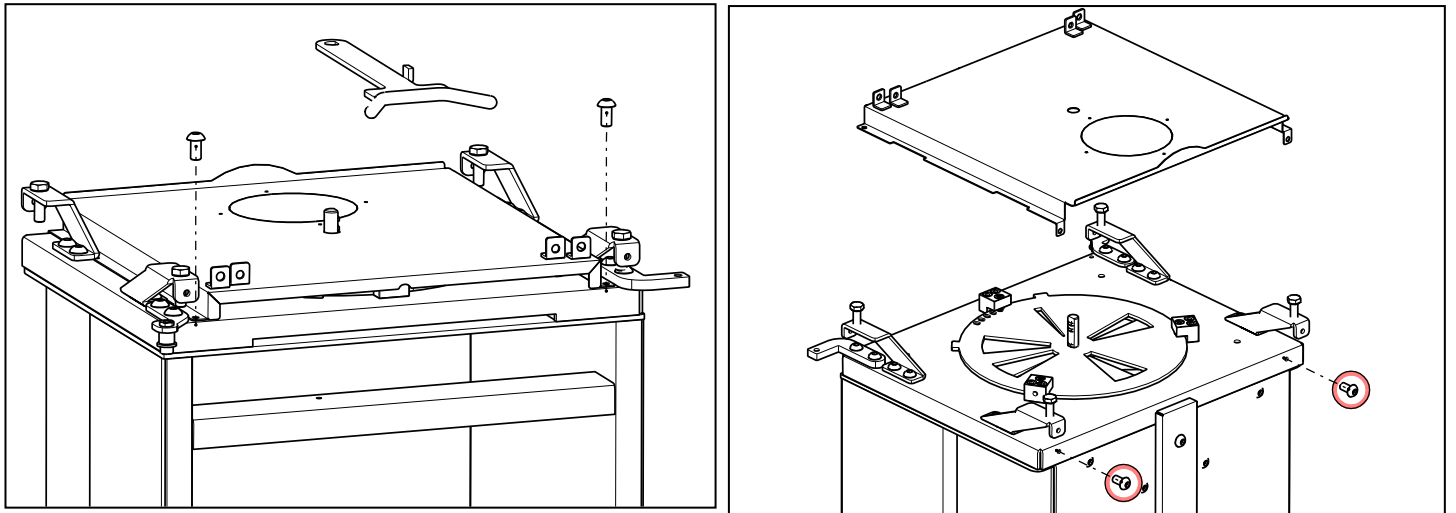

9.11 Adjusting Door Latch. If the door latches click back into their closed position when opening the door then they need a simple adjustment to correct positioning in relation to the door latch pins mounted on the stove body. Loosen the fixing screws slightly and then slide the latch assembly towards the edge of the door (towards the latch pin mounted on the stove

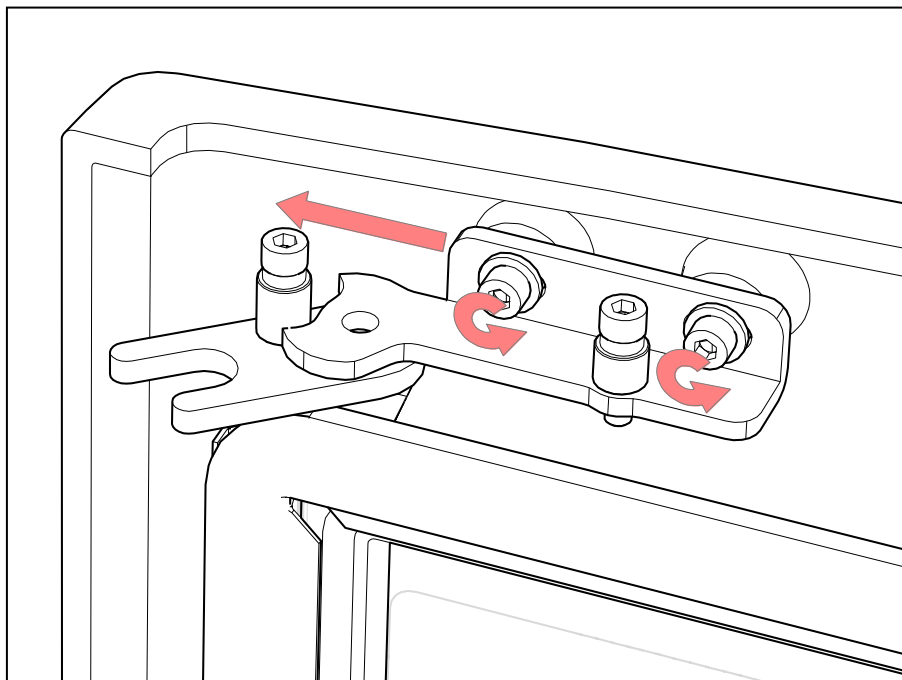

body). Re-tighten in the new position. If the latch still does not click fully open when opening the door proceed to adjust the pin position on the stove body as follows:

9.12 Adjusting Latch Pins (mounting on stove body). The latch pin can be adjusted to enable the latch assembly on the door to catch fully. Firstly slacken the mounting screws slightly. Now tap the end of the bracket towards the centre of the stove. This will increase engagement with the door latch forks. Now re-tighten the bracket fixing screws.

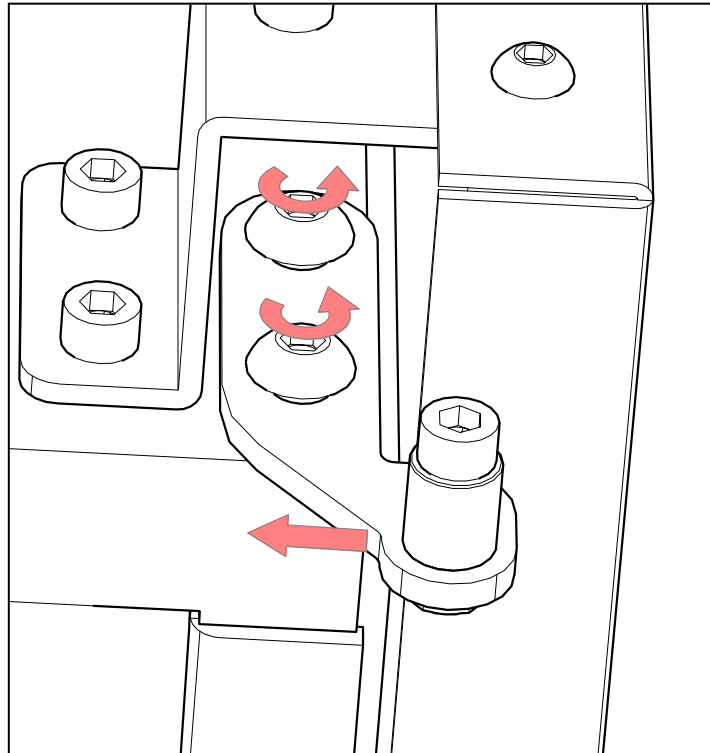

NOTE: If the latches still fail to open fully when the door is opened even after adjusting both latches and latch pins then the door hinges will need adjusting to bring the whole door towards the latch pins on the right side of the stove.

10.1 Purevision 5kW Slimline Stove Principal Dimensions

All Dimensions shown in mm.

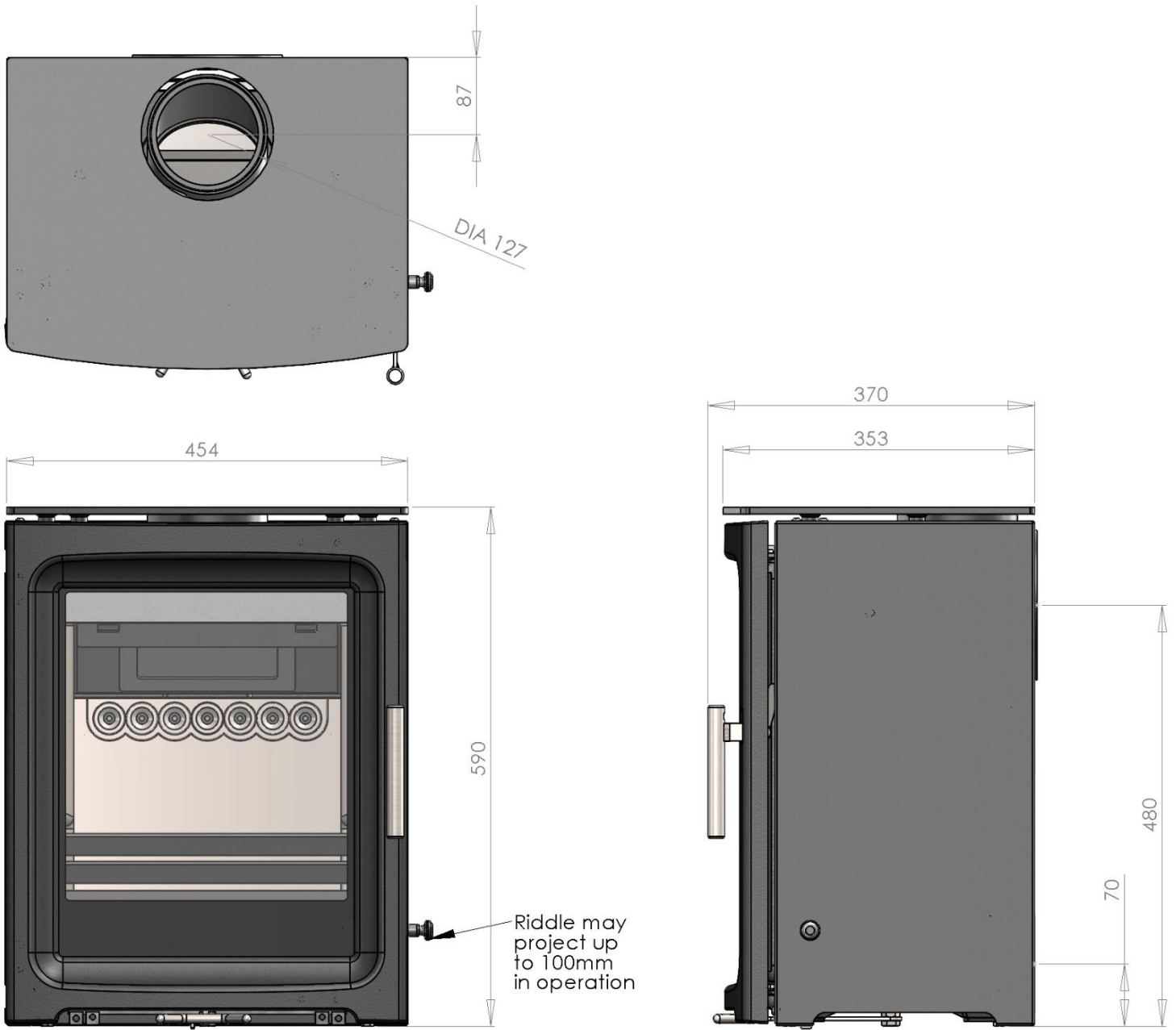

10.2 Purevision 5kW Stove Principal Dimensions

All Dimensions shown in mm.

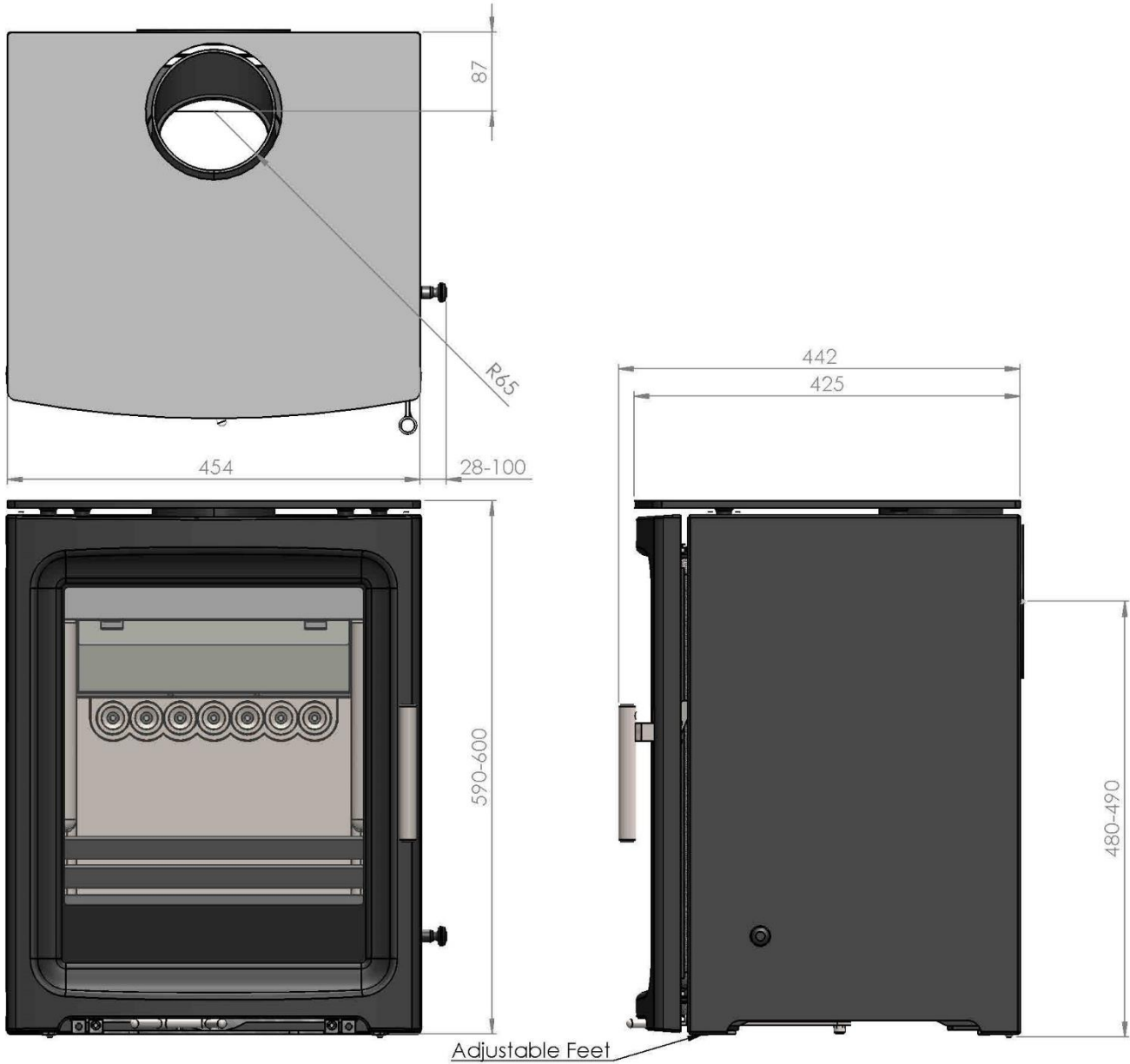

10.3 Purevision 5kW WIDE Stove Principal Dimensions

All Dimensions shown in mm.

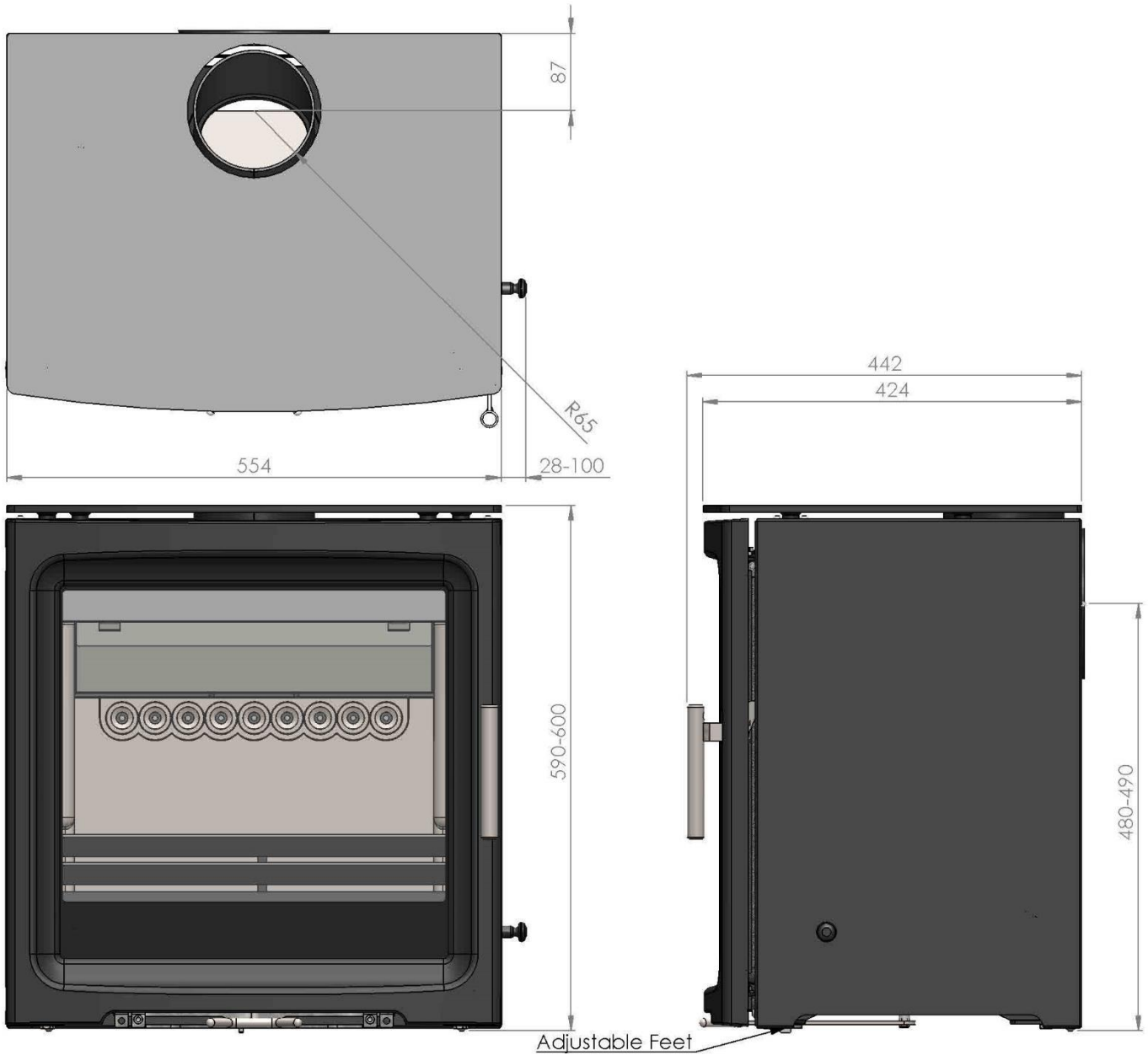

10.4 Purevision 5kW WIDE Slimline Stove Principal Dimensions

All Dimensions shown in mm.

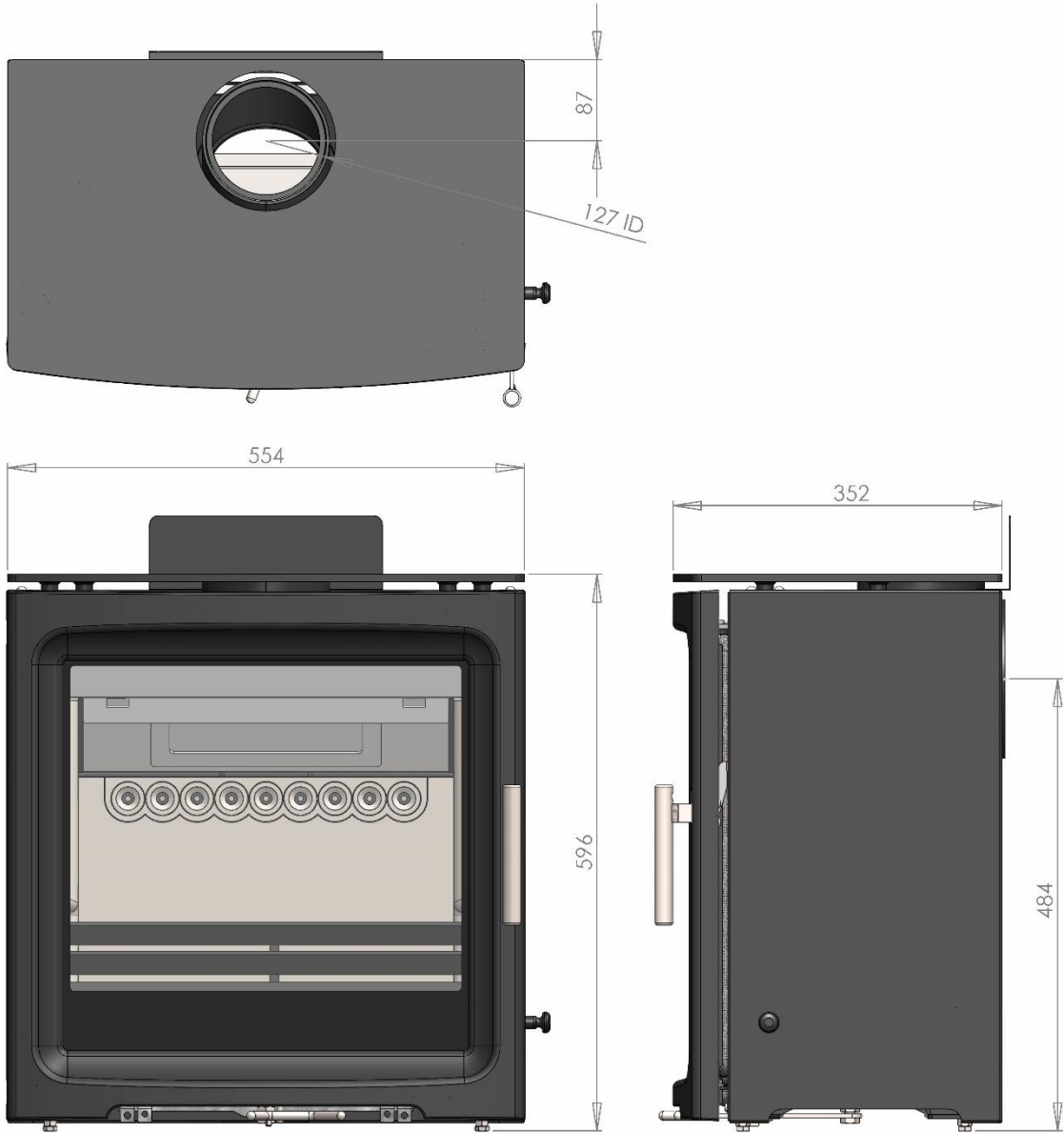

10.5 Purevision 8.5kW Stove Principal Dimensions

All Dimensions shown in mm.

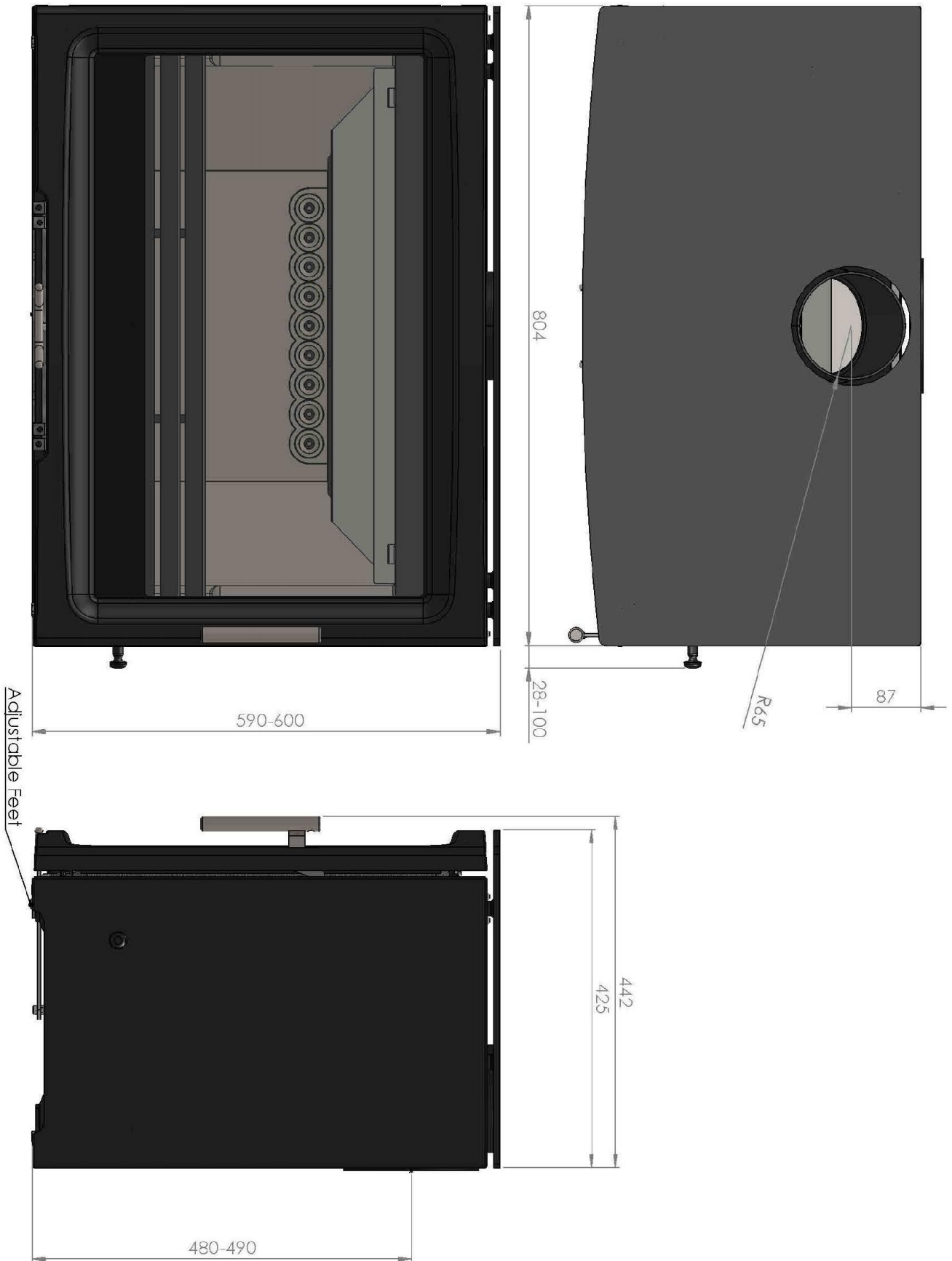

11.0 Frequently Asked Questions

1 Do stoves require a chimney or a liner? All of our stoves require a suitable chimney or professionally installed flue system. A liner may or may not be required depending on flue conditions and only your installer can confirm. Our stoves do not mandatorily require a liner.

2 How do I clean the chimney? You will require a chimney sweep to clean the chimney. It is essential to provide a dedicated chimney cleaning access door when installing the flue of the stove in some situations. In many situations the chimney can be swept through the firebox.

3 Who should install my stove? Fireline want you to enjoy the maximum performance from your appliance. To ensure this, it is essential that they are installed correctly. We strongly recommend that your stove is installed by a suitably qualified installer e.g HETAS or OFTEC.

4 How do I regulate the heat output? Each stove has various air controls, which will allow you to easily regulate the heat output. Output can also be varied by log size and quantity fired.

5 What warranty do I get? Fireline will replace, free of charge, any part that fails (under normal operating conditions) within 12 months of purchase. Consumables such as glass, firebox lining boards or stove rope and adhesives are not guaranteed. We do not accept consequential or incidental liability claims from any product failure. **A call out charge will apply if our engineer attends any stove problem that is not related to product failure.**

6 Where can I get spare parts? Your local Fireline stove retailer will be pleased to supply spare parts and to provide any other information you require. Alternatively contact Fireline.

7 Can the doors be left open while burning? For safety and heat efficiency the doors should remain closed. These stoves are not designed or approved for doors open operation.

8 Why is the stove smoking when lit? A flue with lack of draught problems is almost certainly the cause of a smoking stove. Also check adequate ventilation is present - if opening a window or door stops the smoking then lack of ventilation is the probable main cause. A qualified fitter should complete both a smoke pressure and flow test prior to fitting the stove to ascertain the integrity of the flue.

9 Why should I "Run in" my stove? To begin, light a series of small fires over a period of a few days to allow the paint finish to cure. The stove is finished with a highly heat resistant paint. The finish can be renovated with stove paint available from your stove retailer. If the stove is not "run in" correctly, this may cause the paint to discolour and flake.

10 What is Over Firing? Over firing is overheating your stove by having the fire burning too fiercely. Your stove should never be used in a manner to cause over firing. Over firing can be caused by over loading the stove with fuel or leaving air controls fully open or operating the stove with leaking or defective door rope seals. If any part of stove glows red hot then your stove is over firing and your air control should be adjusted to reduce airflow to stove immediately. Over firing can cause permanent damage to the appliance, which is not covered by warranty.

Fireline UK - A division of Charlton & Jenrick Ltd
Unit D Stafford Park 2, Telford, Shropshire, TF3 3AR
T: 01952 200 444 F: 01952 200 480 www.charltonandjenrick.co.uk
A Charlton and Jenrick Group Company