



fireline™
PUREVISION



LPV 3 Sided Stoves



LPV Linear Purevision Freestanding Stove Range
5kW & 8kW Nominal Outputs.

Installation and Operating Instructions

Please hand these instructions to the stove user when the installation is complete. Leave the stove ready for operation and instruct the user in the correct use of the appliance and operation of controls.

Important: – These products must be installed by a suitably qualified installer.

Clean Air Act Exemption

The Purevision LPV 5 5Kw & LPV8 8kW stoves only have been exempted under the Clean Air Act 1993 to burn seasoned wood logs in designated smokeless zones in the UK. This is subject to the correct fitting of the air control plate (the part and fitting instructions are packed separately) maintaining the air wash control at a minimum opening at all times. **Instructions for wood burning MUST be followed in order to ensure compliance at all times.**



Fireline UK – A division of: Charlton & Jenrick Ltd
Unit D Stafford Park 2, Telford, Shropshire, TF3 3AR
T: 01952 200 444 F: 01952 200480
www.charltonandjenrick.co.uk
A Charlton and Jenrick Group Company



PLEASE READ ALL THESE INSTRUCTIONS CAREFULLY!

For safety reasons it is essential that your stove is correctly installed and operated. Fireline cannot accept responsibility for any fault or consequential problems arising through incorrect installation or operation.

TABLE OF CONTENTS

<u>Section</u>	<u>Page No</u>
1. List of Components.....	4
2. Component Identification and Controls.....	4
3. Preparation of Stove for Installation.....	5
4. Important Safety Information.....	6
4.1 Warnings and important safety information.....	6
4.1.1 Instructions.....	6
4.1.2 Chimney Warning.....	6
4.1.3 Extractor Fan Warning.....	6
4.1.4 Cleaning & Chimney Sweeping.....	6
4.1.5 Fuels.....	7
4.1.6 Maintenance.....	7
4.1.7 Ventilation.....	7
4.2 Health and Safety Information.....	7
4.2.1 Handling.....	7
4.2.2 Fire Cement.....	7
4.2.3 Asbestos.....	7
4.2.4 Metal Parts.....	7
5. Installation Information.....	7
5.1 Chimney & Flue.....	7
5.2 Ventilation.....	8
5.3 Direct Outside Air Connection.....	8
5.4 Flue Draught.....	8
5.5 Connection to Chimney.....	8
5.6 Material Clearance Dimensions.....	9
5.6.1 Distances from Combustible Materials.....	9
5.6.2 Distances from Non Combustible Materials.....	10
5.7 Hearths.....	10
5.8 Accessories.....	10
5.9 Commissioning & Handover.....	10
6. Technical Data & Declaration of Performance.....	12

Cont'd.....

7. Operating Instructions	13
7.1 Safety Notes for your guidance	13
7.1.1 Fireguards	13
7.1.2 Modifications	13
7.1.3 Overfiring	13
7.1.4 Fume Emission	13
7.1.5 Chimney Fire	13
7.1.6 CO Alarms	13
7.2 Warnings	14
7.3 Clean Air Act (Smoke Control Zones)	14
7.4 Air controls	15
7.4.1 Single Air Control	15
7.4.2 Air Wash	15
7.4.3 Tertiary Air	15
7.4.4 Ceramic Base	16
7.5 Cleaning	16
7.6 Fuels	16
7.7 Important Notes for Wood Burning	17
7.7.1 Refuelling on to a low Firebed	17
7.7.2 Fuel Overloading	17
7.7.3 Operation with Door Left Open	17
7.9 Lighting the stove	18
7.10 Re-fuelling	19
7.11 Shutting down	19
7.12 Shutting down for prolonged periods	20
7.13 User Maintenance	20
8. Active Baffle System	21
8.1 Description	21
8.2 Operation	21
8.3 Adjustment	22
8.4 Removable Sections	22
9. Maintenance Guide	22
9.1 Removing Top Plate	22
9.2 Removing Door	22
9.3 Removing Door Glass	22
9.4 Removal or inspection above baffle	22
9.5 Removing Firebox Liners and Fuel Retainer	22
9.6 Removing Ceramic Base	23
9.7 Firebox Cleaning	23
9.8 Removing Flue Spigot Collar	23
9.9 Removing Rear Casing	23
9.10 Removing Side Casing	23

Cont'd.....

9.11 Removing Side Glass Panels.....	23
9.12 Door Hinge Adjustment.....	23
9.13 Smoke Control Air Limiter.....	23
9.14 Maintenance of Air Control Valve.....	23
9.15 Adjusting Door Spring Latch Forks.....	23
9.16 Adjusting Latch Pin Rollers.....	24
10. Dimensions.....	25
10.1 LPV 5.....	25
10.2 LPV 5 inc Log Store.....	26
10.3 LPV 5 inc Legs.....	27
10.4 LPV 5 inc Pedestal with Drawer.....	28
10.5 LPV 8.....	29
10.6 LPV 8 inc Log Store.....	30
10.7 LPV 8 inc Legs.....	31
10.8 LPV 8 inc Pedestal with Drawer.....	32
11. Frequently Asked Questions.....	35

2.0 Component Identification and Controls

List of Components

Description of Parts	Qty
Purevision Stove Assembly	1
Flue Spigot Collar (installed)	1
Casing upper Blanking Plate	1
Stove Operating Gloves	1
Purevision Toolkit	1

Fig 1 – Purevision LPV Stove Assembly and controls. 5kW model shown.

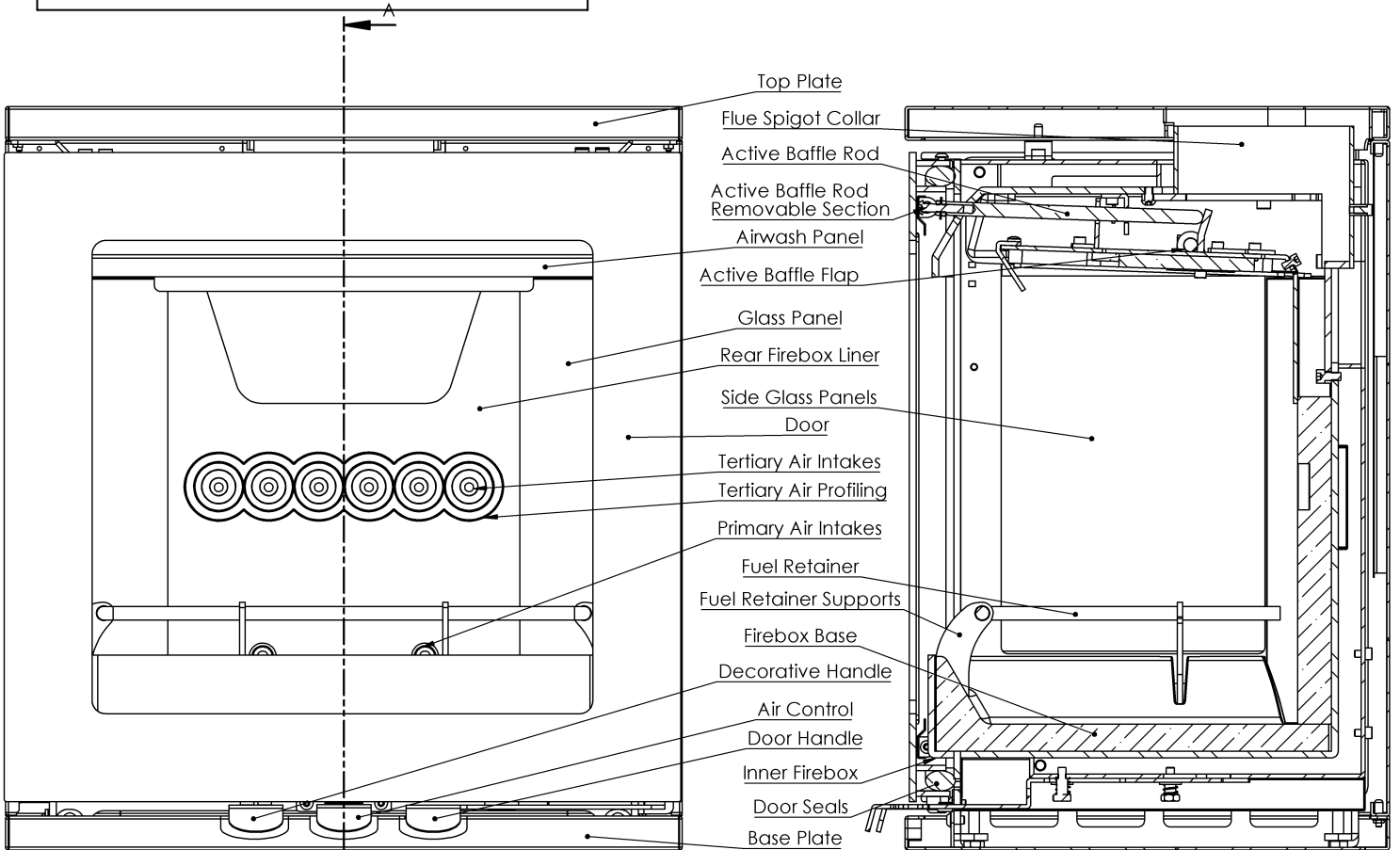
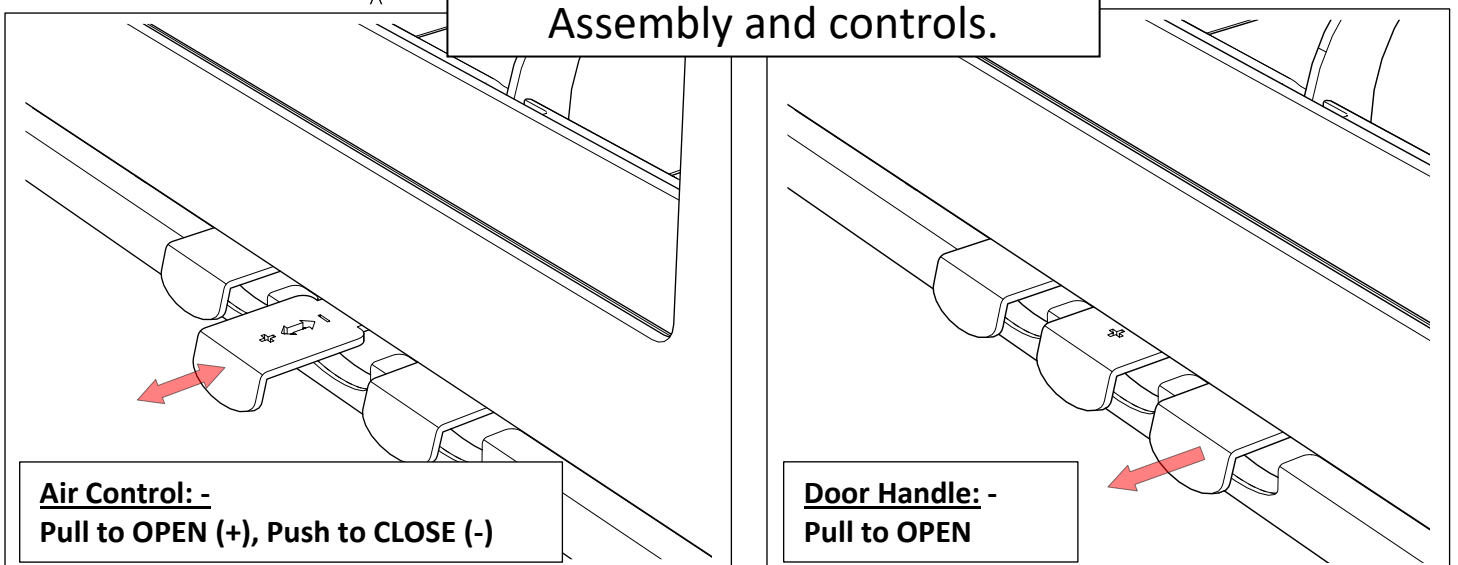

Fig 2 – Purevision LPV Stove Assembly and controls.

SECTION A-A



3.0 Preparation of Stove for Installation.

Your stove comes fully assembled, checked and packed in a protective plywood crate.

Carefully remove the straps and lift off the top and upper crate. Remove any plastic packaging, open the door and remove all the contents. See List of Components section (above) and check contents carefully.

- 3.1.** Remove the top plate by lifting it off.
- 3.2.** If required remove the rear casing by removing rear casing brackets and lifting it off.
- 3.3.** Remove the interior components of the stove using the following procedure. SEE ALSO MAINTENANCE GUIDE section for diagrams where required.
 - 3.3.1.** Remove the baffle plate by supporting the plate with both hands and lifting the front edge towards you and sliding the back edge off the back support and down slightly into the firebox. Once the rear is lowered then the front edge can also be lowered off the front baffle supports.
 - 3.3.2.** Next remove the fuel retainer bar and its supports by lifting the supports carefully out of the slots in the base ceramics.
 - 3.3.3.** Now remove the rear firebox liner(s). Handle and store these ceramic liners very carefully to one side where they will not get broken.
- 3.4.** Rock the stove to the rear and left and right side in turn and set the adjustable feet of the stove until they stand proud of the base casing – or remove them if the stove is to be mounted onto a stand, pedestal, wall mounting bracket or log store.
- 3.5.** The flue spigot collar may now be configured for horizontal connection if required.
 - 3.5.1.** Remove the 6 x M6 cap screws within the upper rear firebox and remove the spigot assembly.
 - 3.5.2.** The rear casing blanking plate is pre-cut by laser can now be taken out by removing the retaining tabs which hold it in place.
 - 3.5.3.** Finally, the spigot may then be rotated by 180 degrees and re-fitted horizontally either using the gasket provided or re-sealing with fire cement or suitable high temperature fireproof sealant as required.
 - 3.5.4.** The casing upper blanking plate can now be used to cover the hole in the top plate.
 - 3.5.5.** The casing infill plate is used to cover the upper area above the horizontal rear spigot.
- 3.6.** Lift the stove into its final position using an assistant to help.
- 3.7.** Make the connection to the flue, chimney or liner using appropriate adjustable rigid flue pipe or adaptor, making sure to seal all joints carefully.
- 3.8.** Now proceed to complete the installation of the stove according to these instructions, Building Regulations and current installation standards or HETAS advice.
- 3.9.** The internal parts of the stove can be re-assembled as the reverse of the previous removal instructions.

4.0 Important Safety Information

4.1. WARNINGS AND IMPORTANT SAFETY INFORMATION

4.1.1. READ THESE INSTRUCTIONS CAREFULLY BEFORE INSTALLATION!

These instructions cover the basic principles to ensure satisfactory installation of the stove, although detail may need slight modification to suit particular local site conditions. In all cases the installation must comply with current local regulations including Building Regulations, Local Authority Byelaws and other specifications or regulations including UK or EU standards referred to as they affect the installation of the stove. Approved Document J is particularly important for England and Wales and can be downloaded for no cost at:

<https://www.gov.uk/government/publications/combustion-appliances-and-fuel-storage-systems-approved-document-j> Also of importance are Approved Documents (A.D.) L1 A and B conservation of fuel and power. The Domestic Heating Compliance Guide will also be found useful.

In addition to these instructions the requirements of BS 8303 and BS EN 15287 must be fulfilled. The installation of a stove is a notifiable building works as defined in the building regulations and it is a legal requirement under England and Wales Building Regulations that the installation is either carried out under Local Authority Building Control approval or is installed by a Competent Person registered with a Government approved Competent Persons Scheme, e.g. HETAS or OFTEC amongst others.

4.1.2. Important Chimney Warning

This stove must not be installed into a shared chimney that serves any other heating appliance.

4.1.3. Extractor Fan Warning

There must not be an extractor fan fitted in the same room as the stove as this can cause the stove to emit fumes into the room. If unavoidable the appliance must be checked for spillage in operation with the fan running. Approved Document (A.D.) 1.21 refers. Take any necessary remedial action.

4.1.4. Cleaning and Chimney Sweeping

The appliance, flue & chimney must be cleaned and checked internally and externally regularly in use and especially after a period of disuse (e.g. after summer). Lift down the baffle at least weekly to check for build up of soot or debris on the top from the flue pipe. Remove the baffle and check the flue spigot and connector is fully clear at regular intervals. The chimney and flue connector must be swept at least annually, more often when used with sooty fuels or damp wood. The chimney or flue can usually be swept through the appliance. A wire centred sweeps brush with guide wheel is recommended. Any loose, broken or leaking joints or flue ways **MUST** be repaired immediately.

4.1.5. Fuels

Only use recommended fuels which is dry, well seasoned (or kiln dried) wood logs. The appliance can be damaged by burning petroleum coke, liquid fuels or general rubbish and this will invalidate your warranty and risk your personal safety. **The appliance must not be used as a rubbish incinerator.**

4.1.6. Maintenance

Annual checking and servicing of the appliance and flue by a competent engineer is recommended.

4.1.7. Ventilation

Adequate ventilation is ESSENTIAL for the safe and efficient operation of any solid fuel or wood burning appliance. Ventilation MUST be provided where required by the stove output or flue under-performance. Keep all ventilation clear and free of blockage, including the direct outside air connection where used. See VENTILATION in INSTALLATION INFORMATION section.

4.2. Health And Safety Precautions

Special care must be taken when installing this stove to meet all requirements of the Health & Safety at Work act.

4.2.1. Handling

Adequate facilities must be available for unloading and site handling. Stoves are very heavily built so always ask for assistance when lifting and siting them. See Technical Data for weights.

4.2.2. Fire Cement

Some types of fire cement are caustic and should not be allowed to come into contact with the skin. In case of skin contact, wash immediately with plenty of water.

4.2.3. Asbestos

This stove contains no asbestos. If there is a possibility of disturbing any asbestos in the course of installation then please seek specialist guidance and use appropriate protective equipment.

4.2.4. Metal Parts

When installing or servicing this stove, proper care should be taken to avoid the possibility of personal injury. Injury may be caused by component weight, sharp parts or trapping for example and these risks should be identified and minimised.

5.0 Installation Information

5.1. Chimney/flue

The chimney height and the position of the chimney terminal should conform to Building Regulations. **Minimum chimney height is 4.5m and the recommended minimum diameter is 150mm wherever possible for safety margin and performance.** The chimney must be swept before connection to the stove. Check that the chimney is in good condition, dry and free from cracks and obstructions. The diameter of the flue should not be less than 125mm (spigot diameter) at any point and not greater than 200mm. If any of these requirements are not met, the chimney should be lined by a suitable method. When using a liner, a 6" diameter is strongly recommended where it can be used but failing that a 5" flexible flue liner is permitted be used for Purevision stoves providing that the users only burns smokeless fuel or seasoned wood logs with the air limiter fitted in in full accordance with the wood burning instructions.

Where the chimney is believed to have previously served an open fire installation, it is possible that the higher flue gas temperature from the stove may loosen deposits that were previously firmly adhered, with the consequent risk of flue blockage. It is therefore recommended that the chimney be swept a second time within a month of regular use after installation.

If you have any doubts about the suitability of your chimney, consult your local dealer/stockist or chimney specialist. If there is no existing chimney then either a solid fuel compatible prefabricated block chimney or a twin-walled insulated stainless steel flue to BS 4543 can be used. These chimneys must be fitted in accordance with the manufacturer's instructions and Building Regulations.

5.2. Ventilation

Document J of the Building Regulations states that purpose provided ventilation is not required in the majority of houses in England and Wales unless the appliance nominal rated output is greater than 5kW. Over 5kW 5.5 cm² of ventilation (550mm²) is required for every kW output above 5. For example 6.5 kW requires 8.25 cm² and 8 kW needs 16.5cm². In any case, if difficulty in starting the fire or any excessive fuming is experienced, ventilation must be put in place as required to eliminate these flue problems. If a flue draught stabiliser is fitted then extra ventilation is required. See Document J of the Building Regulations for detailed guidance especially in new build properties. A specifically designed direct outside air connection may be used with these stoves to provide 100% of the required combustion air to appropriate levels of ventilation (significantly in excess of the above requirements) directly to the stove and chimney as follows. NOTE: in order to register the installation with HETAS as of early 2016 certain extra evaluation and checking is required if using an outside air connection. If the direct air kit is used and no ADJ vent is installed then a direct registration with Building Control may also be possible.

5.3. Direct Outside Air Connection

Purevision stoves are supplied with the facility of using a dedicated 100mm diameter direct connection duct through a suitable route to the outside air. This will supply 100% of the air required for combustion and operation of the flue. It can be connected to the rear or underside of the stove and should be fitted at the time of stove installation. Only the approved kit for Purevision stoves should be used. This is designed to supply all the necessary air for safe combustion and operation of the stove – ***providing there is no depressurisation of the property by mechanical or other types of ventilation, the flue, chimney and ventilation duct are working correctly, and properly maintained clear of obstructions or leaks etc.*** The kit supplies all the primary, secondary and tertiary air to the stove and also provides room ventilation in excess of the Document J Building Regulations during re-fuelling via the air connection unit under the stove and so subject to no depressurisation (as above) may be used where mechanical ventilation and heat recovery (MVHR) units are used. Some additional instructions for installation are provided with the dedicated kit supplied. NOTE: in order to register the installation with HETAS as of 2016 certain extra evaluation and checking is required if using an outside air connection. If the direct air kit is used and no ADJ vent is installed then a direct registration with Building Control may also be possible.

5.4. Flue Draught

A flue draught at the flue collar of minimum 2.2mm to a maximum 3.5mm water gauge (22 to 35 Pascals) is required for satisfactory appliance performance. This relates to 12-25 Pascals at the tapping on EN13240/13229 test rigs. The flue draught should be checked under fire at high output and, if it exceeds the recommended maximum, a draught stabiliser should be fitted so that the rate of burning can be controlled to prevent over-firing.

5.5. Connection to the Chimney

This appliance is **not** suitable for use in a shared flue.

Whilst 150mm diameter flue or liner is recommended wherever possible, a suitable 5” flexible flue liner is permitted be used on Purevision stoves providing that they only burn smokeless fuel or seasoned wood logs with the air limiter fitted in in full accordance with the wood burning instructions.

An existing fireplace opening can be bricked up or sealed with a register plate. A short length of suitable quality rigid flue pipe of a minimum 125mm internal diameter may then be used to connect the stove to the chimney. A maximum of 150mm horizontal flue pipe can be used unless flue calculations are carried out to allow for a greater length. This flue pipe should conform to Building Regulations. If the connecting pipe enters the vertical flue way at any other angle except vertically, ensure that the pipe end is no closer (along the direction of the pipe) than 76mm to the side or rear chimney walls. Ideally, the old fireplace should be filled in so that there is a smooth streamlined entry into the flue way. It is essential that all connections between the stove and chimney-flue are sealed and made airtight with sealing rope, clamping rings and/or fire cement or heat resisting cement where required.

Both the chimney and flue pipe must be accessible for cleaning and if ANY parts of the chimney cannot be reached through the stove (with baffle removed), a soot door must be fitted in a suitable position to enable this to be done.

5.6. Material Clearance Dimensions

5.6.1. Safety Distances from Combustible Surfaces:

FREESTANDING MODELS

Model	Side (Full wall)	Rear <i>Single Wall Flue</i>	Rear <i>Twin Wall Flue</i>
LPV 5 5kW	650mm	300mm	80mm
LPV 8 8kW	750mm	450mm	200mm

In addition, it is strongly recommended that any furniture or other combustible materials are kept at least 900mm clear from the front of the stove.

NOTE: Combustible surfaces can be protected from radiant heat from the stove by adding non-combustible heat shielding between the stove and the combustible materials with an air gap behind it. By doing so, safe distances may be substantially reduced in practice. BS 8303 Installation of Domestic Heating and Cooking Appliances burning Solid Fuel explains various ways of shielding combustible materials from the heat produced by stoves.

COMBUSTIBLE SHELVES AND BEAMS

Due to the fact that combustible shelves, timber fireplaces and beams have potentially thousands of possible configurations in conjunction with stoves outset or inserted partially or fully into chambers, it is not possible to give firm guidance on dimensions to these features. As a guideline, materials that are in 'line of sight' to the stove are more likely to overheat due to direct radiation from the stove body than materials that are not in 'line of sight' (e.g. with stove fully inside a chamber). Materials above the stove are far more likely to overheat than materials alongside or below. A guideline limiting temperature for solid timber (not surface finishes) is approximately 80-85 degrees C with a normal ambient room temperature. Temperatures of combustible materials can be substantially lowered with a simple heat shield constructed of a non-combustible material and small air gap (6-12mm for example) between the shield and combustible material.

5.6.2. Distances from NON-combustible materials:

The stove can be recessed in a suitable sized non-combustible fireplace but a permanent free air gap of at least 50mm must be left around the sides and top and at least 50mm at the back of the stove to obtain reasonable heat output and for access to the stove for removal and maintenance. A clearance of 150mm will give a better heat output

In accordance with Building regulations all non-combustible walls closer than 400mm to the stove should be at least 75mm thick. For practical reasons the back wall of the fireplace recess and the hearth should be made of non-combustible material.

5.7. Hearths:

Purevision freestanding stoves do not require a constructional hearth beneath them as they do not cause the floor temperature to exceed 100 degrees C. Hearths must be generally level. In all instances a non-combustible superimposed hearth extending fully underneath the stove and forming an apron of at least 225mm at the front of the stove and 150mm on either side must be provided. The superimposed hearth must not be less than 12mm thick and must have a clearly defined edge (change of level) to discourage placing of any combustible materials on or partially over it.

The appliance shall be installed on a floor with adequate load-bearing capacity. If the existing construction does not meet this requirement, suitable measures (e.g. load distributing plate) should be provided to achieve it.

5.8. Accessories

Purevision stoves are provided with a selection of accessories including stands, log store stands, and a dedicated outside air kit. Only use genuine Purevision accessories.

5.9. Commissioning and Handover

CO Alarm: Building Regulations require that whenever a new or replacement fixed solid fuel or wood/biomass appliance is installed in a dwelling a carbon monoxide alarm must be fitted in the same room as the appliance. Further guidance is available in BS EN50292:2002 and from the alarm manufacturer's instructions. Provision of an alarm must not be considered a substitute for either installing the appliance correctly or ensuring regular servicing and maintenance of the appliance and chimney system.

Upon completion of the installation, allow a suitable period of time for any fire cement and mortar to dry out. A small fire may then be lit and checked to ensure the smoke and fumes are taken from the stove up the chimney and emitted safely to atmosphere.

Advise the customer not to run the stove at full output for at 3 – 4 days. Explain that the stoves can provide much more or less output than their rated heat outputs depending upon fuels, fuel loads used and how they are operated.

Warn the customer that using excessive air (having the air controls open too wide for too long) can over-fire and irreparably damage the stove. Damage caused by over firing is NOT covered by any warranty.

On completion of the installation and commissioning, check all parts of the appliance are correctly fitted and ensure that the operating instructions and operating tools (including gloves) for the stove are left with the customer. You must be sure to advise the customer on the correct use of the appliance with the fuels likely to be used on the stove and warn them to use only the recommended fuels for the stove.

Advise the user on what to do should smoke or fumes be emitted into the room from the stove – see **Safety Notes** section. The user should be warned that they **MUST** use a suitable fireguard in the presence of children, aged and/or infirm persons.

6.0 Technical Data & Declaration of Performance and Conformity DoC & DoP

Ecodesign for Energy-Related Products Regulations 2010 UK SI 2010 No 2617 and EU 2015/1186 implementing 2009/125/EC

Manufacturer: Fireline UK Ltd, a Division of Charlton & Jenrick Ltd.

Range Designation: Purevision LPV Linear freestanding stoves.

Models: Purevision LPV 5, 5kW and LPV 8, 8kW with nominal outputs of 5kW and 8kW.

Intended Use: Domestic heating appliances

Independently Performance & Safety tested by: Kiwa Gastec, AB No: 0558/Kiwa Cermet Italia, NB No: 0476

Constasy of Performance System: System 3, ISO9001

Model	Purevision LPV 5 Linear 5kW	Purevision LPV 8 Linear 8kW			Notes
Appliance weight (packed/unpacked) (Kg):	96/86	132/119			
Approximate Output Range: (kW)	3.8-7.1	5.0-9.9			
Harmonised EN European Standard (hEN):	EN13240: 2001 Amd 2: 2004	EN13240: 2001 Amd 2: 2004			
Additional Characteristics Test Standard:	DIN +	DIN +			
Additional Particulate Emission Test Standard:	PD6434	PD6434			
Performance Characteristics using Wood Fuel					
Original Test Report Number and Issue Date:	61395-1 02/2021	61395-2 02/2021			
Total Efficiency: (%)	79.6	76.5			
Declared nominal output: (kW)	5.0	8.0			
Tested nominal Output: (kW)	5.0	7.9			
Tested wood re-fuelling interval: (h)	0.82	0.75			
Flue gas mass flow: (g/s)	4.0	6.4			
Mean CO emission (@13% O ₂): (%) (Nmg/m ³)	0.1 (1250)	0.12 (1500)			
Mean C _n H _m emission (@13% O ₂): (Nmg/m ³)	58	63			
Mean NO _x emission (@13% O ₂): (Nmg/m ³)	93	90			
DIN+ particulates (@13% O ₂): (Nmg/m ³)	20	30			
PD6434 Particulate Emissions High output: (gh ⁻¹)	2.7	2.0			
PD6434 Particulate Emissions Low output: (gh ⁻¹)	1.8	1.5			
Optical Density Time > 0.2 High (Mins)	0.5	0.0			
Optical Density Time > 0.2 Low (Mins)	0.1	0.2			
*Mean Flue Temperature: (Deg C)	283	330			
clearSkies Level	5	4			
Calculated Seasonal Efficiency η _s	69.6	66.5			
EI Energy Rating Category	A	A			
Approximate Max Log Length: (mm)	320	550			
Safety Distances From Combustibles					
Side Wall: (mm)	650	750			
Rear Wall: (mm)	300/80	450/200			

Signed:



Peter Mintoft
Director
February 2021

Note: This document also forms the Declaration of Conformity (DoC) for The Ecodesign for Energy-Related Products Regulations 2010 (2010 No 2617)

NOTE: Refuelling intervals for testing are chosen according to the standards concerned for performance testing and are comparative only. They **do not** relate directly to re-fuelling intervals that can be achieved on an installed product. Re-fuelling intervals of 1-1.5h for wood and 3-4+ hours for briquetted smokeless fuels would be more usual. Under normal conditions on a low air control setting stoves should stay in overnight on suitable briquetted smokeless fuel.

7.0 Operating Instructions

7.1. Safety Notes for your guidance

7.1.1. FIRES CAN BE DANGEROUS – Always use a fireguard to BS 8423:2002 Fireguards for use with solid fuel appliances in the presence of children, the elderly or the infirm.

7.1.2. DO NOT perform modifications to the appliance as this could seriously compromise safety in operation.

7.1.3. DO NOT OVERFIRE – it is possible to fire the stove beyond its design capacity, this could damage the stove, so watch for signs of over firing – if any part of the stove starts to glow red, including baffle plate or fuel retainer, the fire is in an over fire situation and the controls should be adjusted accordingly. Never leave the stove unattended for long periods without first adjusting the controls to a reduced and safe setting – **careful air supply control should be exercised at all times.**

7.1.4. WARNING – FUME EMISSION

Properly installed and operated, this appliance will not emit fumes. Occasional fumes from de-ashing and refuelling may occur which is not normally of serious concern. **However, persistent fume emission is potentially dangerous and must not be tolerated.**

If fume emission does persist, then the following immediate action should be taken: -

1. Open doors and windows to ventilate room
2. Let the fire out, or remove and safely dispose of fuel from the appliance.
3. Check for flue chimney blockage and clean if required.
4. Do not attempt to re-light the fire until the cause has been identified and corrected.

If necessary, seek professional advice from chimney or stove specialists.

Important! – Do not fit an extractor fan in the same room as this appliance.

7.1.5. IN THE EVENT OF A CHIMNEY FIRE

- Raise the alarm to let others in the house know.
- Call the Fire Service
- Reduce the appliance burning rate by closing all air controls fully.
- Move furniture and rugs away from the fireplace and remove any nearby ornaments.
- Place a fireguard or spark guard in front of the stove.
- Feel the chimneybreast for sign of excessive heat.
- Do not relight the fire until the chimney and flue ways have been examined by a professional.

If the wall is becoming hot, move the furniture away. Ensure that the Fire Service can gain access to your roof space in order to check this area for signs of fire spread.

7.1.6. CO ALARMS

Your installer should have fitted a CO alarm in the same room as the appliance. If the alarm sounds unexpectedly, follow the instructions given under “Warning Note” below.

WARNING If the CO Alarm sounds unexpectedly:-

1. Open Doors and windows to ventilate the room and then leave the premises.
2. Let the fire go out.

7.2 Warnings:

This appliance is **not** designed for open operation and therefore should **not** be operated with the doors open.

This stove is designed to burn wood and smokeless fuels cleanly with high efficiency. However, for this product to work properly it must be used correctly. If used correctly this stove will burn with the very useful feature of clean glass.

It is **essential** that the stove has an adequate air supply for combustion and ventilation. DO NOT block any ventilators provided. The primary, secondary and tertiary air inlets must be kept clear of obstruction.

Warning! This appliance will be very **hot** when in operation and due care should be taken when operating the controls. A tool and pair of quality leather gloves are provided to assist safe operation.

Do not use an aerosol spray on or near the stove when it is alight.

7.3 The Clean Air Act 1993 and Smoke Control Areas

Under the Clean Air Act local authorities may declare the whole or part of the district of the authority to be a smoke control area. It is an offence to emit smoke from a chimney of a building, from a furnace or from any fixed boiler if located in a designated smoke control area. It is also an offence to acquire an "unauthorised fuel" for use within a smoke control area unless it is used in an "exempt" appliance ("exempted" from the controls which generally apply in the smoke control area).

In England appliances are exempted by publication on a list by the Secretary of State in accordance with changes made to sections 20 and 21 of the Clean Air Act 1993 by section 15 of the Deregulation Act 2015. Similarly in Scotland appliances are exempted by publication on a list by Scottish Ministers under section 50 of the Regulatory Reform (Scotland) Act 2014. In Wales and Northern Ireland these are authorised by regulations made by Welsh Ministers and by the Department of the Environment respectively.

The Purevision LPV 5, 5kW and LPV 8, 8kW stoves have been recommended as suitable for use in smoke control areas when burning wood logs. This is conditional upon fitting the supplied secondary air control limiters and following the wood burning instructions precisely. Suitable Authorised fuels can also be used in the appliances in Smoke Control Areas (see Authorised fuel list <https://smokecontrol.defra.gov.uk/fuels.php>)

Further information on the requirements of the Clean Air Act can be found here: <http://smokecontrol.defra.gov.uk/>. Your local authority is responsible for implementing the Clean Air Act 1993 including designation and supervision of smoke control areas and you can contact them for details of Clean Air Act requirements.

7.4 Air Controls

Keep air controls and inlets/outlets clean and free from ash or debris at all times. Keep direct outside air inlet grille (if fitted) clean and clear at all times.

Do not leave air control fully open unless monitoring the fire as over firing damage can result which is not covered by any warranty.

7.4.1 Single Air Control Operation

Primary (behind fuel), secondary (air wash) and tertiary air is automatically controlled by the single control lever at the bottom, underneath the stove door. The IN position is the OFF position and closes off combustion air to the firebox. The off position should only be used if absolutely necessary for very slow burning and when burning wood will cause the glass to become blackened, the chimney to gradually become tarred and smoke to be emitted from the stove.

Wood burning: Move the lever fully OUT for maximum air to start or revive a wood fire. Returning the lever towards the IN position will reduce the air supply progressively to reduce the burn rate. The nominal burn rate is usually achieved when the stove is fully warmed up (2-3 loads of logs) and burning dry hardwood logs by having the lever very approximately 18-20mm from the IN position. This is only a rough guide as flue and fuel conditions will vary the required position. The fire will automatically be supplied with the correct mix of secondary and tertiary air for complete combustion. The maximum OUT position conveniently provides a boost of primary air as well to get new fuel burning quickly in order to minimise smoke. Do not leave on maximum setting unless monitoring the fire to ensure over firing damage does not occur.

7.4.2 Air Wash

All Fireline stoves are provided with a sophisticated “air wash” system to assist in keeping the fire as visible as possible and reducing cleaning intervals. This secondary air supply to the stove is controlled through the main single air control. The Clean Air Act air restrictor bracket will deliberately prevent full closure of this control.

7.4.3 Tertiary Air

This appliance is also fitted with a patented tertiary air combustion system that burns otherwise uncombusted gasses in the products of combustion thereby improving efficiency, increasing heat output and decreasing unwanted atmospheric emissions. The Tertiary air supply to the stove is controlled automatically by the draught in the flue and firebox and the single air control. At certain stages of burning you will notice “jets” of swirling flame emerging near the air holes to the rear of the firebox.

7.4.4 Ceramic Base

Your stove is fitted with a ceramic base for efficient burning of wood. A quantity of ash will need removing before each burn but the base does not need to be completely cleared and in fact a build up of wood ash when burning wood will not harm the stove and wood may burn better on thin bed of ash. Excessive wood ash build up is not recommended and will affect ease of operation and increase smoke emissions if allowed to build up too thickly.

7.5 Cleaning

Glass: Despite the advanced air wash system provided, the glass will still need cleaning from time to time depending on the fuel quality and burning rates used. Never clean glass when the stove is hot. Use stove glass cleaner or ceramic hob cleaner, which is available from your stove retailer or supermarket. As an alternative, use a wet cloth with some of the wood ash if burning wood but be very careful to use very clean ash so as not to scratch the glass. DO NOT use coal ash to clean the glass.

Outer body: The outer body simply needs to be dusted or wiped with a clean dry cloth from time to time. DO NOT use any kind of wet cloth, furniture polish or cleaning agent. Do not paint with anything other than your stove suppliers recommended paint or paint specifically for stoves.

Inner firebox: Brush the inside of the firebox clean from time to time to check the integrity of the plates and liners etc. Check the two primary air holes in the lower firebox back panel are kept clear of ash. See Maintenance Guide section for instructions on how to remove parts of the stove. It is not normally necessary to re-paint inside the firebox due to the high temperatures that mean that the paint does not have much effect before being burnt off. Steel and high-quality cast ceramic liners are very resilient firebox materials and will give reliable service without major cleaning or work on the firebox. The ceramic liner boards are very durable but may require replacement from time to time depending upon fuels and the type of usage experienced. Firebox linings are not covered by warranty, as they are a wearing consumable part. Cracks less than 6mm (1/4") or where the steel underneath is not visible are not critical and operation can continue as normal.

Baffle: It is essential to check the top of the baffle for build up of soot and ash regularly when in use and after a long period of disuse – e.g. summer. From time to time remove the baffle if necessary to ensure that the flue way entrance is clear. Remove any fixings in the front brackets and lift the front edge of the baffle upwards and forwards to slide the rear edge off its support. Lower the rear edge and then slide the baffle off its front supports to leave it free for removal. See maintenance section for further details.

Air Supply: It is essential to check the air supply grille on the outside of the property if the direct outside air connection is installed. Regularly brush or vacuum out any debris, cobwebs or similar materials to ensure that the air supply is not restricted. Ensure the air intake chamber visible underneath the ash pit section with the stove door open is kept free of excessive ash or debris.

7.6 Fuels

The appliance is fitted with a woodburning base and the appliance has been tested and approved burning dry, well-seasoned logs. This is the only recommended fuel. For other fuels please contact the manufacturer for advice.

Note: Warning!- Petroleum coke fuels or household waste must not be burnt on this appliance.

Should any difficulties arise over fuel quality or suitability, consult your local approved fuel merchant.

7.7 Important Information for Wood Burning

With a full load of wood and burning near nominal output the stove will need to be refuelled approximately every 1-1.5 hours. One or two large logs will burn longer than a number of smaller ones. Wood can usually be stacked higher in the stove than solid mineral fuel but care must be taken that logs do not touch the baffle or the glass panels. **Do not stack logs above the level of the tertiary air inlet profiling in the rear ceramic firebox liners at the back of the stove.**

Always make sure that flames are visible above the wood after re-fuelling for cleanest burning.

Burning without flames above the fuel will create unnecessary smoke. After re-fuelling open the single air control fully OUT for 3 minutes or until the logs are fully blackened to achieve full flames above the fuel.

Wood burns best on a bed of ash and it is therefore only necessary to remove surplus ash from the stove occasionally to maintain a practical burning level and the rear air intake holes clear.

Burn only dry, well-seasoned wood, which should have been cut, split and stacked - under cover from rain - for at least 12-24 months with free air movement around the sides of the stack to enable it to dry out. Burning wet or unseasoned wood will create tar deposits in the stove and chimney and will not produce a satisfactory heat output. **Wood that is not properly dry ('dry' is considered to be less than 20% internal moisture content) uses up energy from the burn process to evaporate the water inside the wood thus creating very poor conditions for combustion.** The main cause of burning problems with wood stoves is due to excessively damp wood. Wood can appear perfectly dry on the outside but still contain 40-50% water on the inside. A moisture meter can be purchased from stove and equipment suppliers if you wish to check your wood source is correct. Split a log and check the inside as well as the outside.

7.7.1 Refuelling on to a low fire bed

If there is insufficient burning material in the firebed to light a new fuel charge, excessive smoke emission can occur. Refuelling must be carried out onto a sufficient quantity of glowing embers and ash so that the new fuel charge will ignite in a reasonable period. If there are too few embers in the fire bed, add suitable kindling to prevent excessive smoke.

7.7.2 Fuel overloading

The maximum amount of fuel specified in this manual should not be exceeded, overloading can cause excess smoke. Never load fuel above the bottom edge of the tertiary air profiling in the back ceramic firebox liner or allow them to touch the glass. All models max log diameter = approx. 150mm. Max length = 320mm for 5kW, 550mm for 8kW models. One log is acceptable ONLY if loading onto a hot well established fire bed.

7.7.3 Operation with door left open

Operation with the door open can cause excess smoke and spillage into the room. The appliance must not be operated with the appliance door left open.

7.8 Lighting the Stove

We recommend that you have two or three small fires before you operate your stove to its maximum heat output. This is to allow the paint to cure in steadily and to give a long service life of the paint finish. During this curing in process, you may notice an unpleasant smell whilst the finishes finally cure. It is non-toxic, but for your comfort we would suggest that during this period you leave all doors and windows open.

First, open the single air control fully to the left side. Load the firebox with four (six or eight for the larger LPV8 model) fully dry small-medium logs in a crossed pattern.



Next add plenty of dry kindling sticks and a firelighter ON TOP of the 4 logs as shown. A crib lattice pattern tends to work well. Remove the end section of the active baffle operating rod (shown in red below - if fitted) to allow the baffle to remain in the Open IGNITION position during lighting.

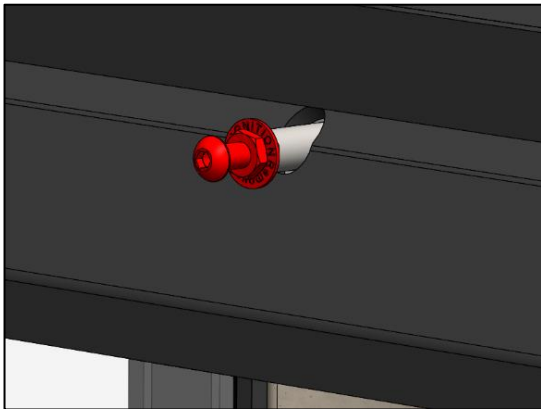

Now light the firelighter(s), leaving the air control fully open and close the door. It will not always be necessary to leave the door open but DO NOT leave the stove unattended if you find it necessary to leave the door ajar.

The kindling will burn and set light to the logs by radiation and breaking down to charcoal gradually and with fewer emissions than the traditional logs on top methods.



Allow the fuel to reach a steady burn and sometimes the initial fuel can be left to burn down to charcoal without much further attention. Build the fire up carefully by adding a couple of small split logs at a time. Do not overload the fire bed with a very big log or more than two logs at a time.



Once you have a good fire bed established across the firebox, further fuel can be added step by step as required. Don't be tempted to overload the fire bed with fuel all at once or close down the air controls until the fire is really well established for some time. Once the ignition period is well under way, close the active baffle operating rod by re-fitting the end section of the rod. Gradually reduce the air control opening to establish the burning intensity you require.

7.9 Re-fuelling

The fire will begin to die down with a significant amount of white ash showing amongst the fuel - the fire will die down as the fuel is consumed. When the flames disappear and the remainder is breaking down into glowing embers it is an appropriate time to consider re-fuelling. NOTE: If the flames disappear and there are still lumps of solid wood left this indicates excessive internal moisture in the wood or insufficient air supply or flue draught – use drier logs, more than one log at a time or adapt the burning technique to burn hotter.

NOTE: To eliminate unwanted smoke emission, after loading new logs on to the fire, open the air wash control up fully for 3 minutes or until the logs are blackened all over to boost the fire and get flames issuing from the top of the fuel as soon as possible. When flames are well established, reduce the air wash to the running setting required. **Burning without flames above the fuel will create unnecessary smoke.** Do not load fuel above the tertiary air inlet hole profiling at the back of the firebox.

Loading 1 or 2 large sized logs at a time weighing 1-2kg DRY will produce a good output with reasonable burn time. Small logs will burn up quickly producing a high output and more emissions for a short time, and a large log will take longer to burn and produce less output and less emissions over a given time unless it will not burn with flames above it. These appliances are approved for intermittent operation on wood (0.75 to 1.5 hour burn cycles) although longer burn times can be achieved by fully loading the firebox, getting the fuel burning well and then shutting the air control right down (see below). The fire will then need reviving by first opening the air controls and then using small pieces of wood and plenty of air to get flames issuing from the wood again. Never load fuel above the rear firebox tertiary air profiling or allow it to spill onto the glass.

7.10 Shutting Down

The stove will normally shut down by itself as the fuel is consumed so there is no need to close the air control towards the end of the burn. In order to shut down the stove for other reasons, close the single air control to the central position. If the control is left in this position, the fire will eventually go out but it will also cause the glass to blacken. If you want to revive the fire it is recommended that the air control is opened fully initially.

Warning! - The stove will remain **very hot** for a considerable time after the fire has died down or been extinguished.

7.11 Shut down for prolonged periods

If the stove is to be left unused for a prolonged period of time then it should be given a thorough clean to remove ash and unburned fuel residues. To enable a flow of air through the appliance to reduce condensation and subsequent damage, leave the air controls open a little way unless downdraught occurs when they may need to be closed. It is important that the flue connection, any appliance baffles or throat plates and the chimney are swept prior to lighting up after a prolonged shutdown period.

7.12 User Maintenance

See also the Cleaning section above and Maintenance Guide Section below for further information. Inspect the inside of the firebox and above the baffle plate every week during use.

Where the chimney is believed to have previously served an open fire installation, it is possible that the higher flue gas temperature from the stove may loosen deposits that were previously firmly adhered, with the consequent risk of flue blockage. It is therefore recommended that the chimney be swept a second time within a month of regular use after installation. **See chimney cleaning section in section Warnings and Important Information.** Inspect the inside of the stove and the flue ways and ensure they are 100% clear after a period of disuse (e.g summer).

Check all rope seals for completeness, wear and that there are no gaps between the ends etc. Any gaps must be eliminated and ropes must be re-adhered to their grooves with suitable rope seal cement where required. Worn or missing rope seals will affect appliance operation, control and emissions output and can lead to overheating damage.

Check all air intakes and outlets within the stove for cleanliness and remove any ash or debris build up by suitable means.

Check outside air ventilators and stove air inlets are clean and unobstructed.

Only use manufacturers recommended replacement parts on the appliance.

8.0 Active Baffle System

8.1 Description: The Purevision LPV range, is fitted with an internal stainless steel active baffle assembly which fulfils a number of functions:

a) IGN Position – end operating rod section removed:

Direct access of ignition heat into flue-way to start up cold, inactive flues in a quicker and more user-friendly way.

b) Auto Position – end section in place:

Opening of the flue way when refuelling to enhance the fume removal capacity of the stove when the door is open.

c) In the case of a low draught flue where it has been improved as far as possible by conventional means (e.g. terminal, increasing height and diameter and reducing bend severity and number where possible) the removable sections of the main baffle can ease gas flow to enable safe use of the stove where otherwise it may not be possible to continue to use a wood burning stove.

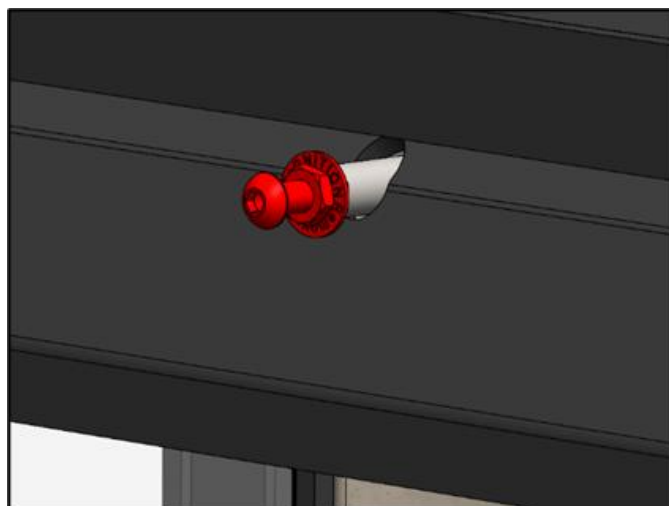

8.2 Operation:

The baffle mode is controlled by the stainless steel rod that protrudes through the air wash panel centrally inside the door of the stove. **The removable end section can be operated when hot only by using the stove gloves supplied with the stove.**

- A) Removing the end section of the operating rod to activate the **IGN** position allows the baffle flap to remain in the open position regardless of the door position, thereby allowing products of combustion straight into the flue pipe during ignition. This heats up the flue quicker to generate draught sooner and enables lower emissions to be produced during a shorter ignition phase.
- B) Placing the removable end section back into the end of the baffle operating rod selects the **AUTO** position where the rod will be depressed by the door as it closes. This causes the baffle flap to open when the door is open and closes it when the door is closed.

8.3 Adjustment:

Firstly check that the baffle is correctly sitting on its mountings and correct any errors and remove any build-up of ash or debris. The degree of closing of the baffle flap is controlled by the operating rod and it should be fully closed when the door is closed. The operating rod is adjustable by screwing in and out the locknut on the removable end section as highlighted in red in the illustration. Screwing the rod outwards (counter-clockwise) causes the baffle to close further when the stove door is closed. Screwing the rod in (clockwise) causes the mechanism to become shorter thereby pushing the baffle less distance when

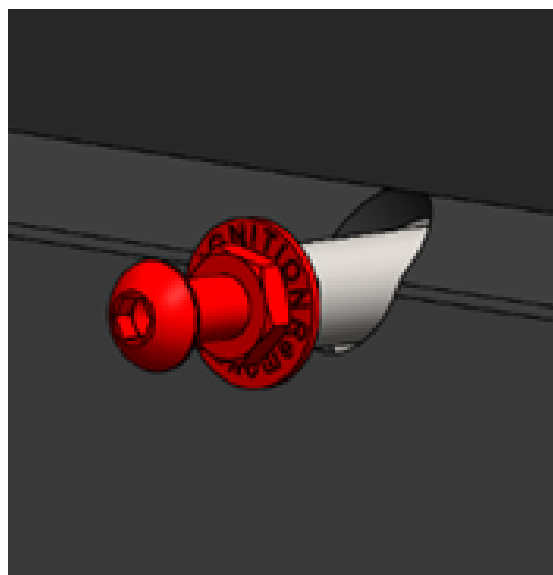

the door is closed. **NOTE: The baffle must be sitting squarely on its supports for this adjustment to be correctly set so firstly remove the baffle from within the firebox and clean the baffle support brackets and top of the rear ceramic.**

8.4 Removable sections:

If the installation is suffering from low flue draught and stove burning operation is sluggish and slow despite known dry high quality fuel being used then the flue should be improved as far as possible. This means removing or at least easing any bends and having them as far up the flue system as possible; using insulated flue as far as possible within and outside of the building; increasing diameter to minimum 6" or above where possible; increasing height of the flue by means of additional terminals or flue lengths; adding anti downdraught or draught increasing cowls before making any changes to the stove. Assuming that stove operation has not improved much once this has been carried out then as a last resort the 'wing' pieces on the upper side of the baffle may be removed to reduce restriction within the stove itself and help to compensate for the lost draught within the flue system.

9.0 Maintenance Guide

- 9.1 Removing Top Plate.** Remove the stove top plate by lifting away. Note the top plate supports for levelling and adjustment as required. It is not necessary to remove the top plate or door to clean or remove items from inside the firebox.
- 9.2 Removing Door.** Remove the stove door by opening to approximately 90 degrees and removing the hinge pin retaining screws top and bottom. Whilst supporting the weight of the door, using a small flat bladed screwdriver, lever up the hinge pins to disengage the hinge pins and free the door assembly. It is not necessary to remove the door to clean or remove items from inside the firebox.
- 9.3 Removal of door glass.** The door glass can be removed with the door open. Slacken the lower window clamp nuts. Slacken and remove the upper window clamp nuts and remove the clamp whilst supporting the glass panel. Carefully move the upper glass edge inwards and lift gently to disengage the glass panel from the bottom clamp. Renew seals if necessary, as no air leaks are permissible around the glass panel. Replace glass in the reverse of removal. Do not overtighten the clamps which can crack the glass.
- 9.4 Removal of or Inspection Above Baffle Plate.** **1.** Lift the baffle assembly upwards at the front and at the same time slide the rear forwards off the back baffle supports which locate on top of the rear ceramic. **2.** Next lower the rear edge into the firebox and allow the front of the baffle to slide off the front baffle support brackets. **3.** Finally rotate the baffle out of the firebox.
- 9.5 Removing Firebox Liners and Fuel Retainer Assembly.** **1.** Lift the fuel retainer supports up and out of their slots in the base ceramics together with the retainer bar. **NOTE: Ensure that the rear firebox liner does not fall forwards and break!** **2.** Remove the rear firebox liner being very careful not to damage the tertiary air profiling at the top centre which is delicate.

- 9.6 Removing Base Ceramic components.** 1. Remove the fuel retainer and rear firebox liner(s) as described previously. 2. Carefully lift out the two or three base ceramic sections according to the model. They may need to be shifted side to side slightly or vacuum ash out from the gaps in between them to help free them up after some time in service.
- 9.7 Firebox Cleaning:** It is important to maintain the two rear primary air holes and the tertiary air holes clear of ash and debris. Ideally use a vacuum cleaner with hose and brush attachment for cleaning.
- 9.8 Removing Flue Spigot Collar.** Unscrew 6 x M6 securing screws from inside the firebox and remove spigot collar. When re-assembling either use a suitable fireproof gasket or fire cement to seal.
- 9.9 Removing Rear Casing.** 1. The top casing can be lifted off. 2. Unscrew screws securing rear casing to brackets at rear of firebox and lift the rear casing away.
- 9.10 Removing Side casing.** 1. Unscrew and slacken 2 x M4 Allen screws from both left and right-side casing upper and lower brackets which are accessible from the front with the door open. 2. The left and right-side panels can then be removed by easing the brackets outwards from behind the screws at the same time as working the rear brackets forward out of their slots.
- 9.11 Removing side glass panels:** 1. Remove steel side panels as described previously. 2. There are four glass clamping brackets per side. These can now be slackened and two removed to make the glass accessible for removal. Replace gaskets as required when re-assembling.
- 9.12 Door Hinge Adjustment.** Door alignment may be adjusted by slackening the door hinge securing bolts after removing the left side panel and re-positioning the hinge to suit. This will adjust the front-back alignment and left side seal tightness. Check the door seals with a paper strip all around after any adjustment to prove they are still sealing correctly. Take care not to over tighten the left (hinge) side as it will cause the right side to be almost impossible to seal.
- 9.13 Smoke Control Air Limiter.** 1. If the stove is to be used to burn seasoned wood logs in a Smoke Control Zone in the UK, the Smoke Control air limiter bracket must be fitted. This bracket prevents the air control being completely closed when the stove is used to burn wood. 2. To attach or remove the bracket, use the 2 x M5 screws provided to fix the air limiter behind the air slider control.
- 9.14 Maintenance of air control valve.** The main air control valve is mounted underneath the air plenum chamber which is fixed immediately beneath the firebox. To access this for thorough cleaning and re-lubrication firstly Invert the firebox for access and remove the outside air box. To remove the outside air box remove 4 x screws from bottom of firebox and lift off the outside air box. The air control slider components can now be removed and cleaned/lubricated as required.

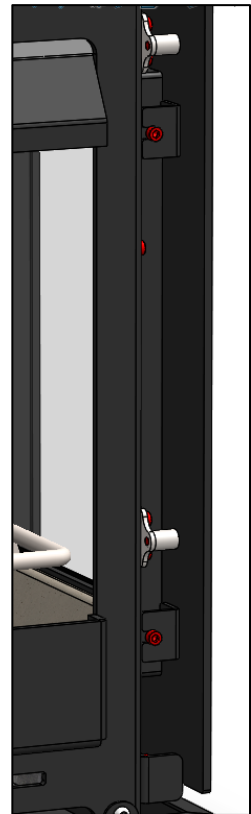

- 9.15 Adjusting Door Spring Latch Forks.** If the door latch forks click back into their closed position when opening the door then they need a simple adjustment to correct their positioning in relation to the door latch pins mounted on the stove body. Loosen the fixing screws slightly and then slide the latch assembly towards the latch pin mounted on the stove body so it becomes closed to its respective pin. Re-tighten in the new position.
- 9.16 Adjusting Latch Pin Rollers (mounted on the stove body).** Both latch pin rollers can be adjusted to enable the latch assembly on the door to catch fully and securely and open fully when the door is opened. Firstly slacken the roller pin bracket mounting screws slightly. Now tap the end of the bracket towards its respective fork on the door. This will increase engagement with the door latch forks. Sliding the pin brackets inwards towards the firebox will increase the spring pressure that the forks can exert. Moving them too far in will prevent the latches locking fully so the right balance has to be struck between a good spring force and the locking action. Retighten the bracket screws and test using a paper strip in the door seal when closed to ensure that the seal is tight.

10.1 LPV 5 5kW Stove Principal Dimensions

All Dimensions shown in mm.

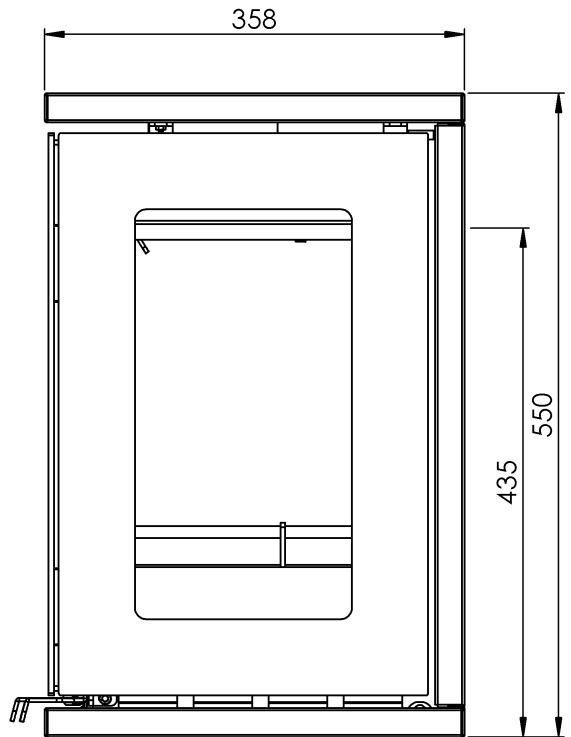
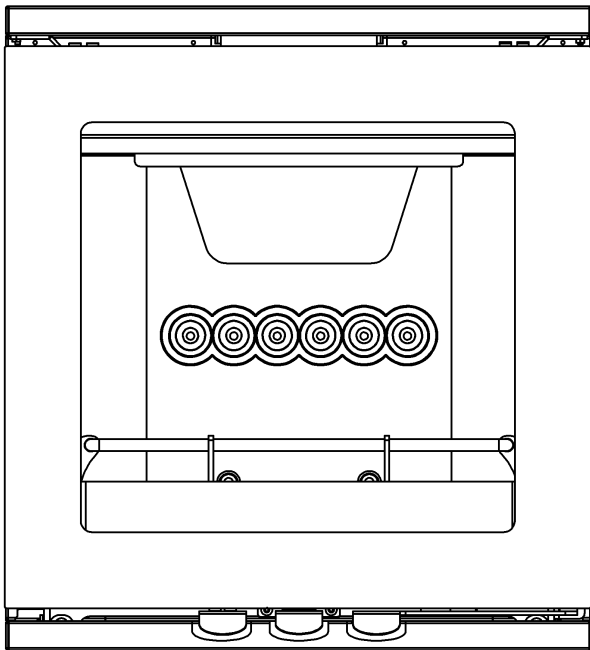
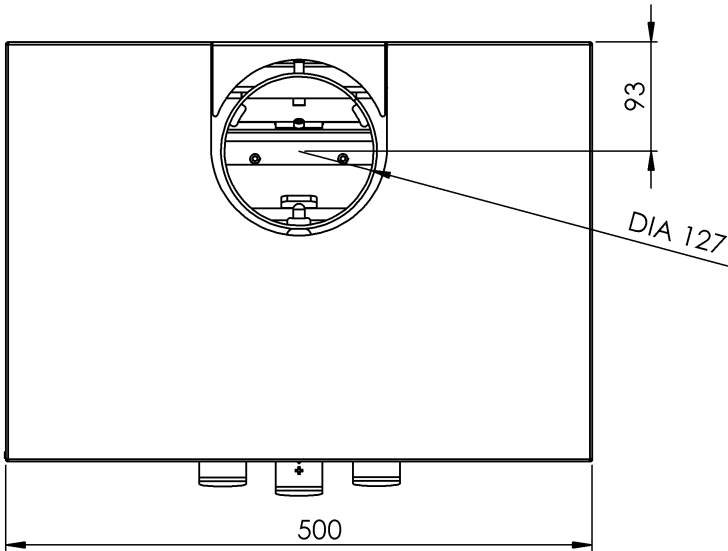

10.2 LPV 5 5kW Stove Principal Dimensions – Log Store

All Dimensions shown in mm.

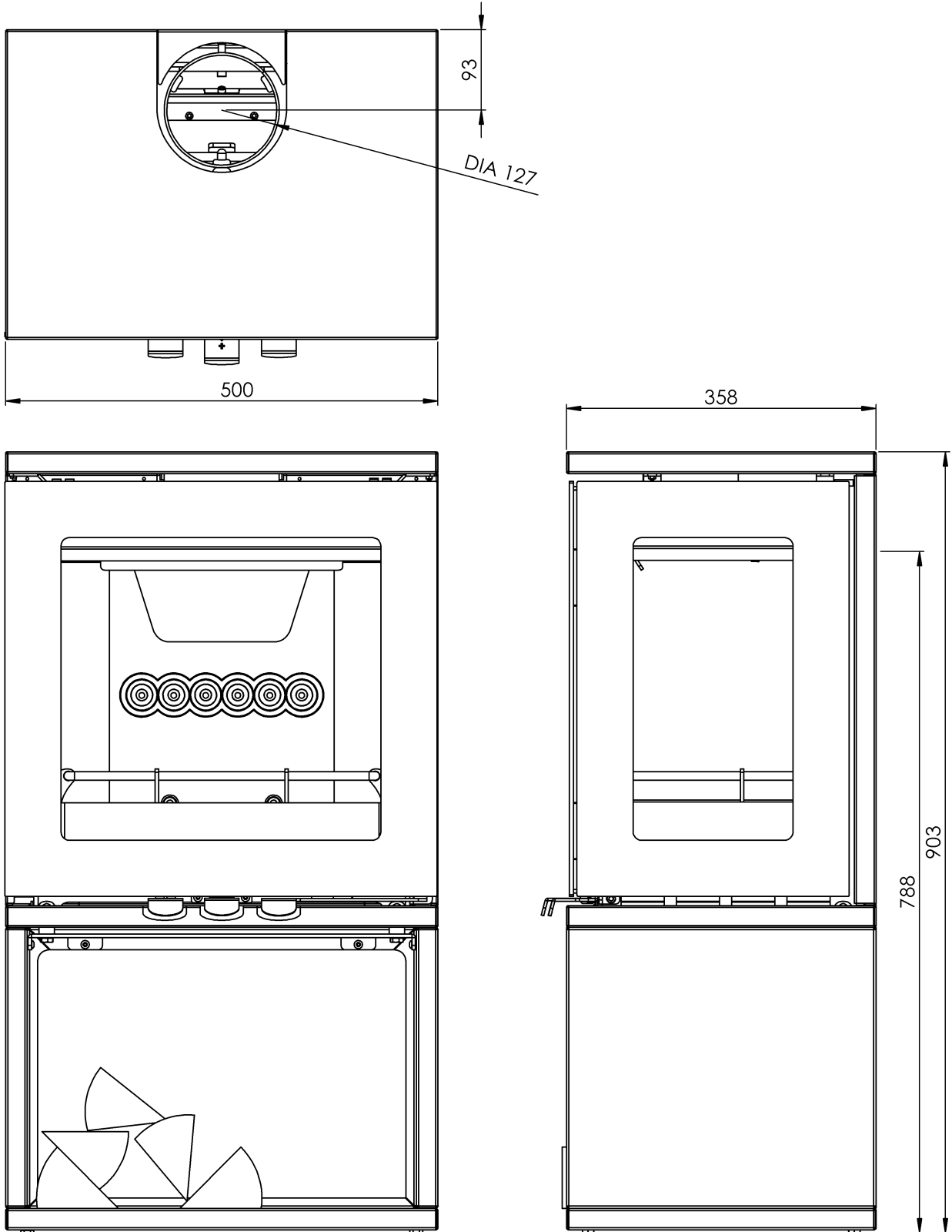

10.3 LPV 5 5kW Stove Principal Dimensions - Legs

All Dimensions shown in mm.

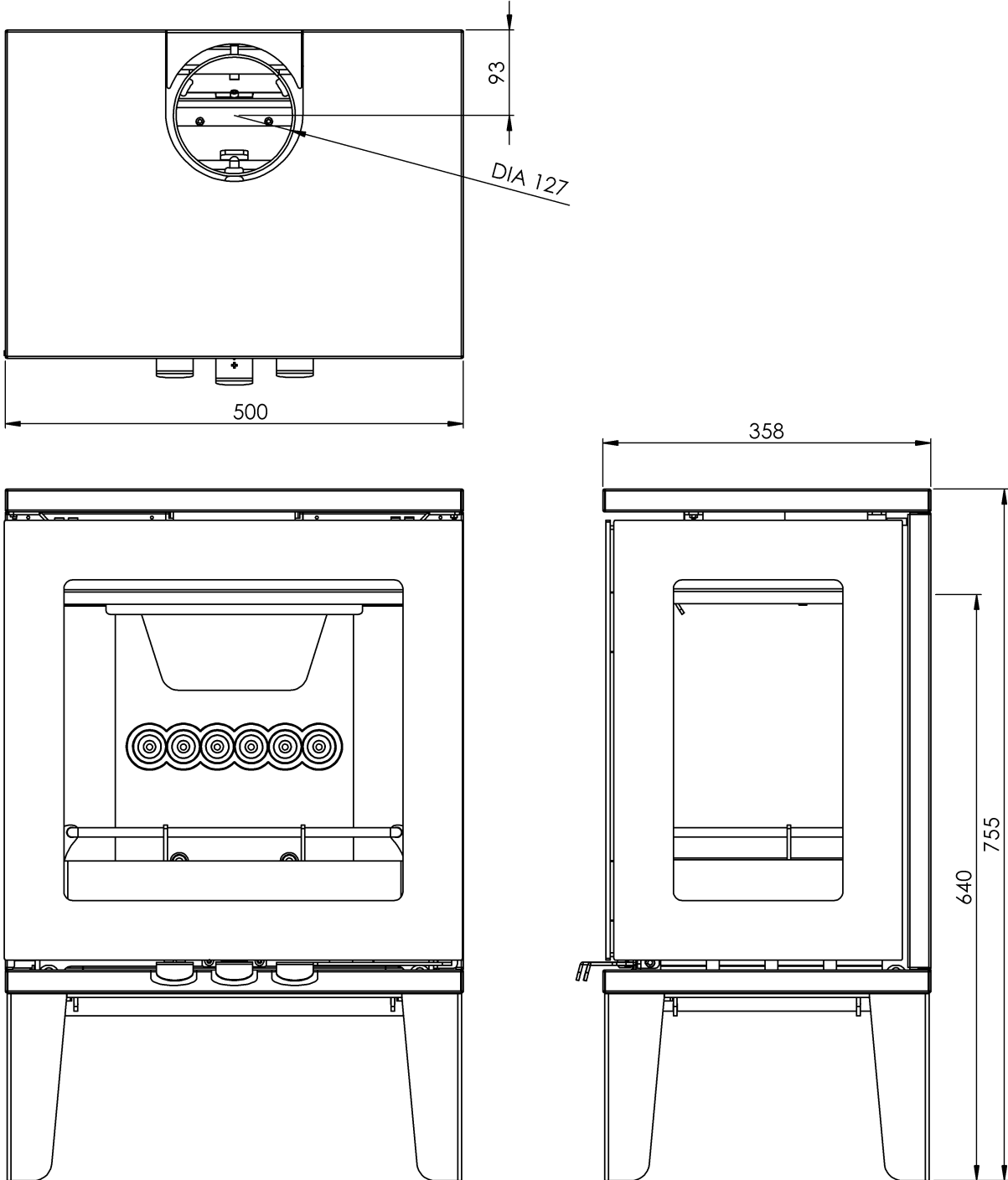

10.4 LPV 5 5kW Stove Principal Dimensions – Pedestal with Drawer

All Dimensions shown in mm.

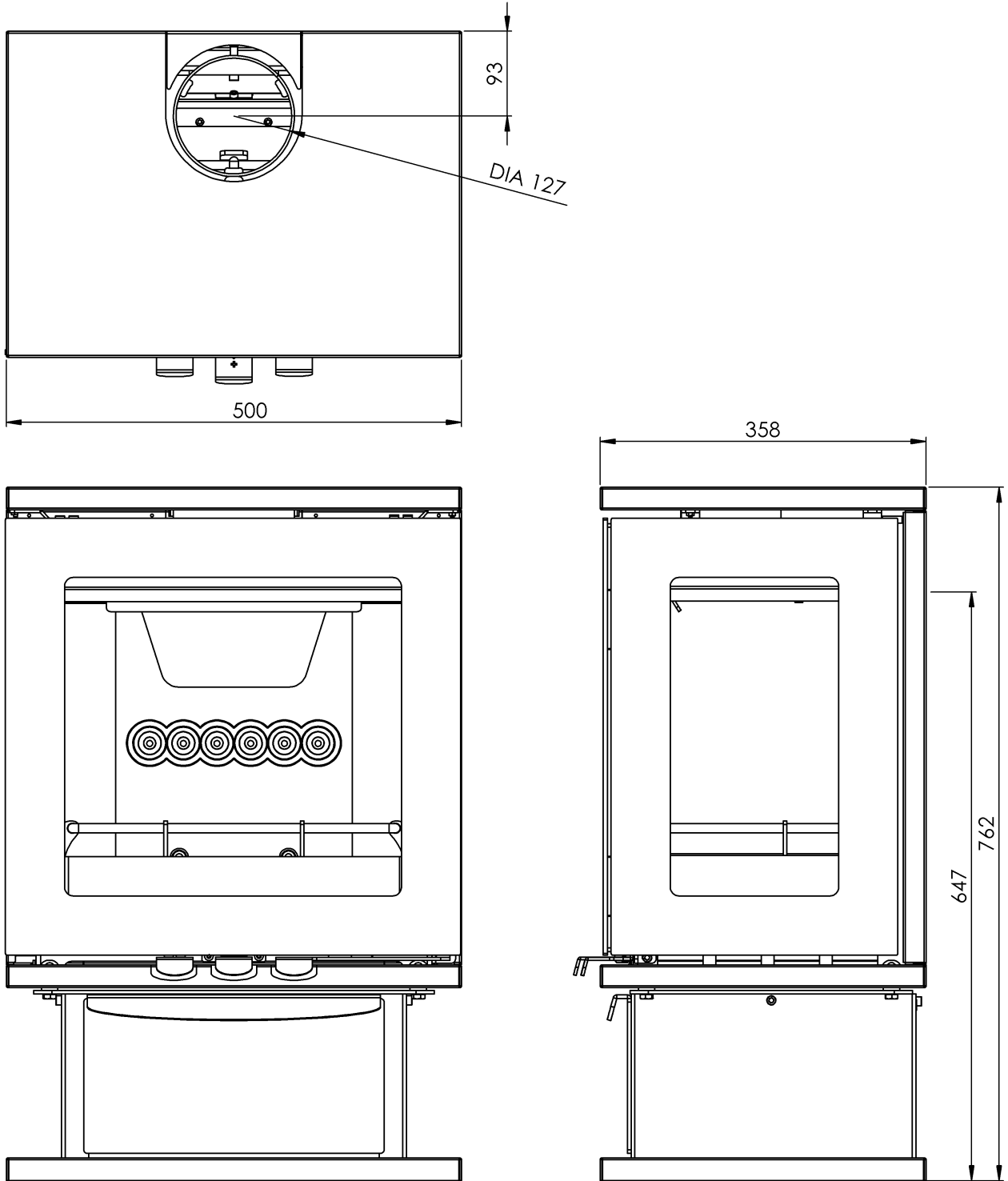

10.5 Purevision 8 8kW Stove Principal Dimensions

All Dimensions shown in mm.

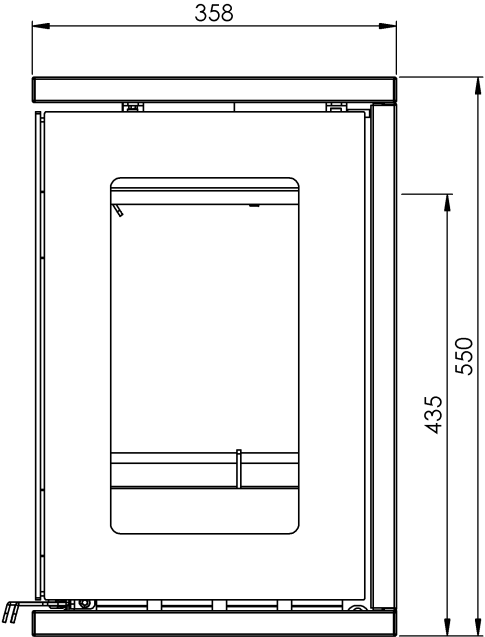
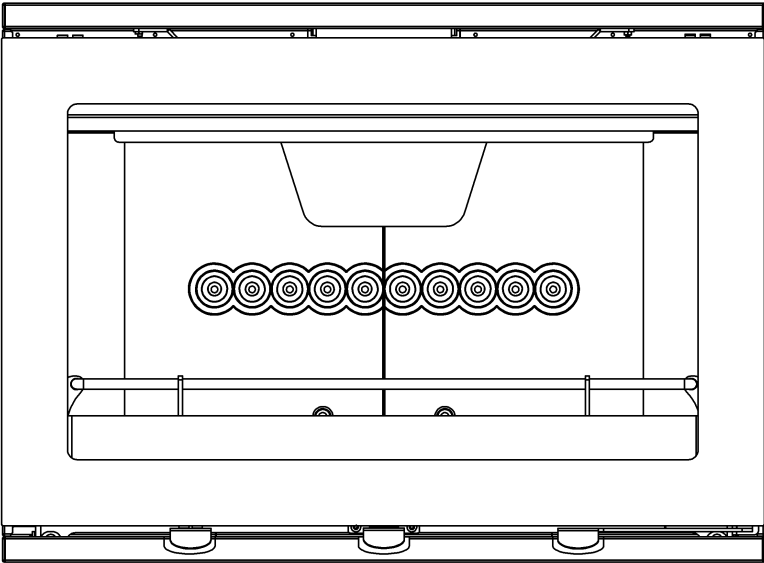
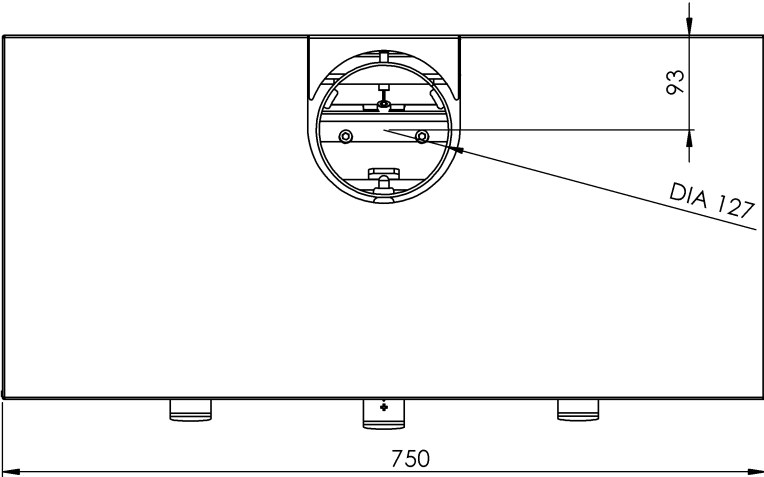

10.6 Purevision 8 8kW Stove Principal Dimensions – Log Store

All Dimensions shown in mm.

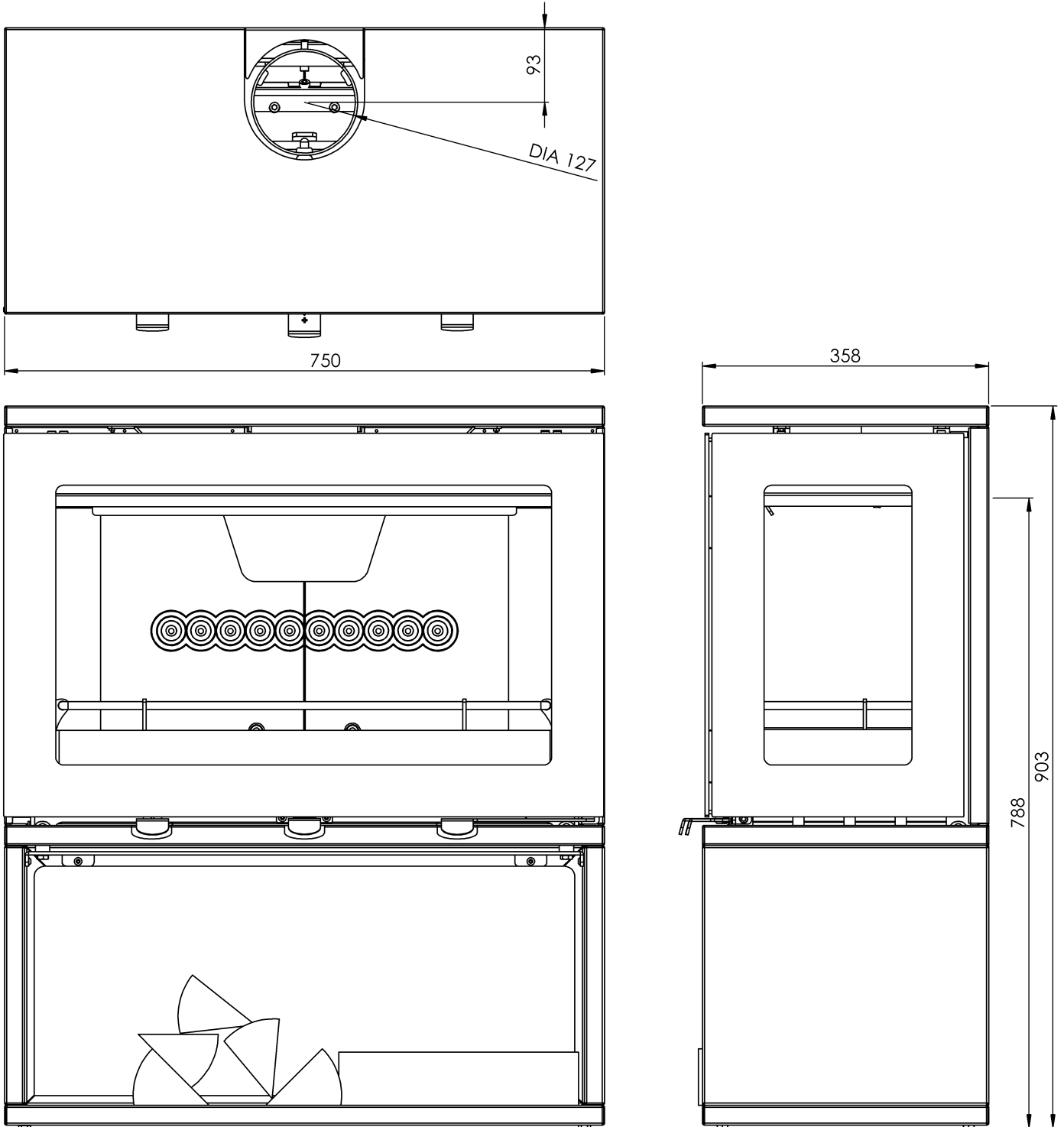

10.7 Purevision 8 8kW Stove Principal Dimensions - Legs

All Dimensions shown in mm.

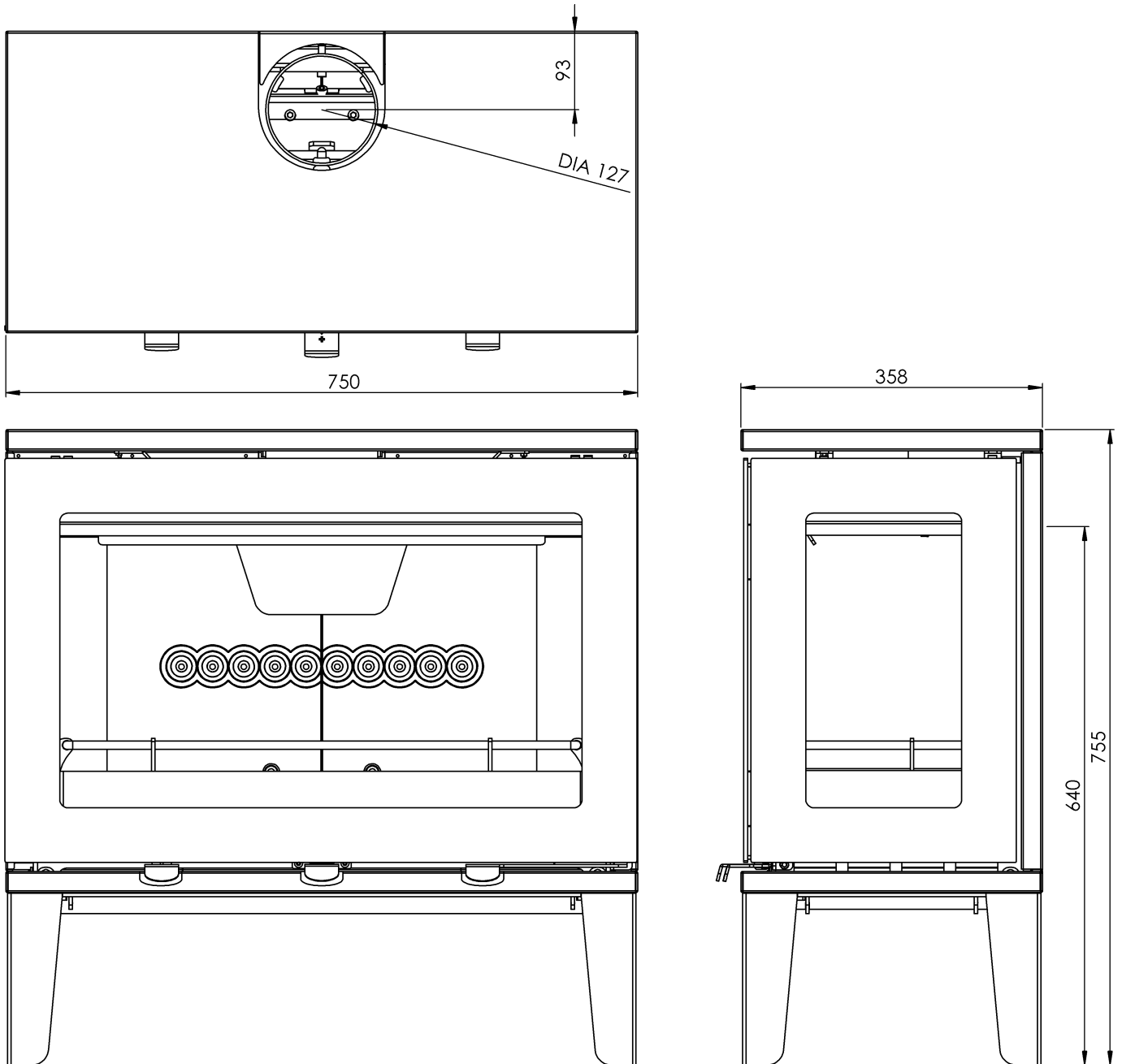

10.8 Purevision 8 8kW Stove Principal Dimensions – Pedestal with Drawer

All Dimensions shown in mm.

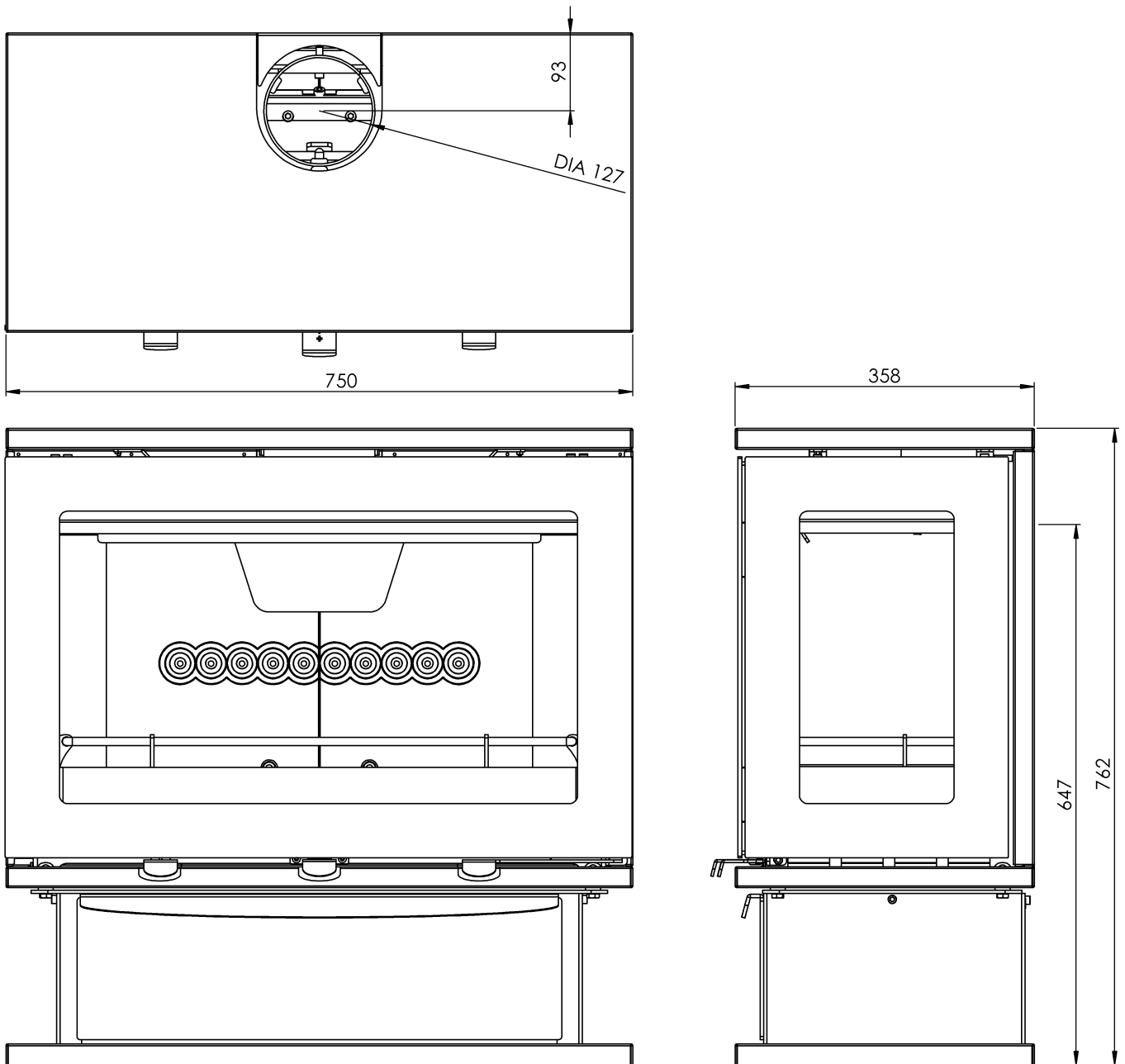

Blank Page

Blank Page

11.0 Frequently Asked Questions

1 Do stoves require a chimney or a liner? All of our stoves require a suitable chimney or professionally installed flue system. A liner may or may not be required depending on flue conditions and only your installer can confirm. Our stoves do not mandatorily require a liner.

2 How do I clean the chimney? You will require a chimney sweep to clean the chimney. It is essential to provide a dedicated chimney cleaning access door when installing the flue of the stove in some situations. In many situations the chimney can be swept through the firebox.

3 Who should install my stove? Fireline want you to enjoy the maximum performance from your appliance. To ensure this, it is essential that they are installed correctly. We strongly recommend that your stove is installed by a suitably qualified installer e.g HETAS.

4 How do I regulate the heat output? Each stove has various air controls, which will allow you to easily regulate the heat output. Output can also be varied by log size and quantity fired.

5 What warranty do I get? Fireline will replace, free of charge, any part that fails (under normal operating conditions) within 12 months of purchase. Consumables such as glass, firebox lining boards or stove rope and adhesives are not guaranteed. We do not accept consequential or incidental liability claims from any product failure. **A call out charge will apply if our engineer attends any stove problem that is not related to product failure.**

6 Where can I get spare parts? Your local Fireline stove retailer will be pleased to supply spare parts and to provide any other information you require. Alternatively contact Fireline.

7 Can the doors be left open while burning? For safety and heat efficiency the doors should remain closed. These stoves are not designed or approved for doors open operation.

8 Why is the stove smoking when lit? A flue with lack of draught problems is almost certainly the cause of a smoking stove. Also check adequate ventilation is present – if opening a window or door stops the smoking then lack of ventilation is the probable main cause. A qualified fitter should complete both a smoke pressure and flow test prior to fitting the stove to ascertain the integrity of the flue.

9 Why should I “Run in” my stove? To begin, light a series of small fires over a period of a few days to allow the paint finish to cure. The stove is finished with a highly heat resistant paint. The finish can be renovated with stove paint available from your stove retailer. If the stove is not “run in” correctly, this may cause the paint to discolour and flake.

10 What is Over Firing? Over firing is overheating your stove by having the fire burning too fiercely. Your stove should never be used in a manner to cause over firing. Over firing can be caused by over loading the stove with fuel or leaving air controls fully open or operating the stove with leaking or defective door rope seals. If any part of stove glows red hot then your stove is over firing and your air control should be adjusted to reduce airflow to stove immediately. Over firing can cause permanent damage to the appliance, which is not covered by warranty.

Fireline UK – A division of Charlton & Jenrick Ltd
Unit D Stafford Park 2, Telford, Shropshire, TF3 3AR
T: 01952 200 444 F: 01952 200 480 www.charltonandjenrick.co.uk
A Charlton & Jenrick Group Company