

Owner's Manual

INCLUDES

User, Maintenance, Service, and Installation
Instructions



Edge & Edge 3s CF GAS STOVE



Keep this booklet for service log and future reference

IMPORTANT



This appliance is guaranteed for 24 months subject to conditions. The 3-year extended parts warranty will only be valid if the annual service recommended in this manual has been completed and the appliance has been registered online.

For use in Great Britain and Ireland.

Literature NO 8229 (ISS 1)

Contents

EXTENDED FIVE YEAR PARTS WARRANTY	2
Benchmark Scheme	3
SECTION ONE Introduction (Users Instructions)	5
SECTION TWO Operating the Appliance (Users Instructions).....	7
SECTION THREE Cleaning (Users Instructions)	7
SECTION FOUR Fuel Bed Cleaning and Layout (Users Instructions).....	9
SECTION FIVE General Points (Users Instructions)...	15
SECTION SIX Appliance Data (Installation Instructions).....	22
SECTION SEVEN Regulations and Warnings (Installation Instructions).....	24
SECTION EIGHT Siting the Appliance (Installation Instructions).....	25
SECTION NINE To Install the Appliance (Installation Instructions).....	32
SECTION TEN Checking Operation of Fire (Installation Instructions).....	35
SECTION ELEVEN Maintenance (Maintenance Instructions).....	37
GAS FIRE COMMISSIONING CHECKLIST.....	41
SERVICE RECORD.....	42

EXTENDED THREE YEAR PARTS WARRANTY

In order to validate your extended 3 years parts warranty please read the Benchmark Scheme on the opposite page and ensure your installer has filled in the appropriate checklist.

This in no way reduces your statutory rights

Your warranty commences from the date of purchase and you must retain your receipt or invoice as proof of a purchase date.

THIS EXTENDED WARRANTY SPECIFICALLY EXCLUDES GLASS AND SOFT REFRACTORY COMPONENTS, THE BULB AND ANY BATTERIES.

Terms and Conditions

1. The appliance must be installed by a GAS SAFE registered person.
2. The appliance must be used in accordance with the user's instructions.
3. The appliance must be serviced annually by a GAS SAFE registered person.
4. The benchmark and service log must be correctly filled out and the record of annual services must be up to date and supported by receipts in each case.
5. This warranty is not transferable and relates to the original installation only.
6. The appliance has not been subjected to misuse or accident or been modified or repaired by any person other than the authorised employee or authorised representative of Charlton and Jenrick Ltd.
7. The registration form must be returned within 1 month of purchase.

Technical Help Desk 01952 200 444



Charlton and Jenrick Ltd is a licensed member of the Benchmark Scheme which aims to improve the standards of installation and commissioning of domestic heating and hot water systems in the UK and to encourage regular servicing to optimise safety, efficiency and performance. Benchmark is managed and promoted by the Heating and Hotwater Industry Council. For more information and the full code of practice please visit www.centralheating.co.uk

Please ensure that the installer has fully completed the Benchmark Checklist on the inside back pages of the installation instructions supplied with the product and that you have signed it to say that you have received a full and clear explanation of its operation. The installer is legally required to complete a commissioning checklist as a means of complying with the appropriate Building Regulations (England and Wales).

All installations must be notified to Local Area Building Control either directly or through a Competent Persons Scheme. A Building Regulations Compliance Certificate will then be issued to the customer who should, on receipt, write the Notification Number on the Benchmark Checklist.

This product should be serviced regularly to optimise its safety, efficiency and performance. The service engineer should complete the relevant Service Record on the Benchmark Checklist after each service.

The Benchmark Checklist will be required in the event of any warranty.

It is a requirement that the gas fire is installed and commissioned to the manufacturer's instructions and the data fields on the commissioning checklist completed in full.

To instigate the guarantee, the gas fire needs to be registered with the manufacturer within one month of the installation.

To maintain the guarantee, it is essential that the gas fire is serviced annually by a Gas Safe registered engineer. The service details should be recorded on the Benchmark Service Interval Record and left with the householder.

Important

For future reference we suggest you record the following details here, and keep the receipt as proof of purchase. This information may be asked for when you contact the helpdesk.

MODEL:	Edge & Edge 3s GAS STOVE	Serial No.	
---------------	-------------------------------------	-------------------	--

This information can be found on the label attached to the packaging and on the data badge, which is located on the back of the door of the appliance.

Retailer Name:	
Address:	

Important: – These products must be installed by a suitably qualified Installer.

Installer information required to register for the extended warranty

Name:	
Date of installation:	
Gas safe number:	

SECTION ONE Introduction (Users Instructions)

Consumer Protection Information

As manufacturers and suppliers of heating products, we take every care, as far as is reasonably practicable, that these products are so designed and constructed as to meet the general safety requirement when properly used and installed. To this end, our products are thoroughly tested and examined before despatch.

IMPORTANT NOTICE: Any alteration that is not approved by the appliance manufacturer could invalidate the approval of the appliance, operation of the warranty and could affect your statutory rights.

Health and Safety Notice

Important

This appliance could contain some of the materials, indicated below, that could be interpreted as being injurious to health and safety. It is the users / installers responsibility to ensure that the necessary personal protective clothing is worn when handling these materials, see below for information.

Artificial Fuels, Mineral Wool, Insulation Material, Refractory/Ceramic Fibres, Glass Yarn - *may be harmful if inhaled, may be irritating to skin, eyes, nose and throat.*

When handling *avoid inhaling and contact with skin or eyes. Use disposable gloves, facemasks and eye protection. After handling wash hands and other exposed parts. If a vacuum is used for cleaning the Logs or cleaning after servicing / installation it is recommended that it be of the type fitted with a HEPA filter.*

Disposal of refractory/ceramic materials. To keep dust to a minimum these materials should be securely wrapped in polythene and be clearly labelled 'RCF waste'. These materials are not classified as 'hazardous waste and should be disposed of at a site licensed for the disposal of industrial waste.

Introduction

- The Edge / Edge 3s has been designed and tested for use in GB (Great Britain) and IE (Ireland).
- The Edge/ Edge 3s incorporates a single gas valve which selects ignition pilot, with variable setting between low and high setting and is operated via remote control hand device.
- The Edge incorporates a safety device in the form of an Oxygen Depletion System, which constantly monitors the oxygen in the room and will cause the fire to switch off if the oxygen level reduces, for instance due to insufficient ventilation or a blocked flue.
- If this regularly occurs do not attempt to relight the appliance until a qualified engineer has checked it, the problem may not be due to lack of air or a defective flue.
- Like all appliances incorporating an aerated burner a low frequency noise may be heard, this may be more noticeable on the low setting. To obtain an authentic fire sound, a noise maybe noticeable from the burner.

Important Information

- The appliance is for use on Natural Gas (G20 @ 20mbar) or LPG Propane Gas (G31 @ 37mbar)Only.
- The chimney or flue (unless new or previously used with a gas appliance) shall be swept before installation if it has been used for solid fuel.
- Failure to install appliance correctly could lead to prosecution.

In GB (Great Britain), the appliance must be installed by a competent person i.e. GAS SAFE registered, in accordance with the GAS SAFETY (INSTALLATION AND USE) REGULATIONS, The Building Regulations (or The Building Regulations (Scotland) or The Building Regulations (Northern Ireland)) and The Current I.E.E. Wiring Regulations, if appropriate.

In IE (Ireland), the appliance must be installed by a competent person and installed in accordance with the current edition of I.S.813 Domestic Gas Installation, the current Building Regulations and the current ETCI rules for electrical installation, if appropriate.



- The glass front of this fire acts as a dress guard, conforming to BS 1945 (1997) however; a fireguard conforming to BS6539 (1997) must be used to protect young children, the elderly or infirm.
- The appliance **MUST NOT** be used with the glass safety screen removed or if it is damaged or cracked.
- During initial firing, an odour may be evident. This is the starch binder used during the manufacture of the fibre components of the fire, and there are **no harmful** effects produced.
- During the normal operation of the fire some black staining may appear on some parts of the fuel bed. This is quite normal and adds to the appearance of the appliance. However, if excessive black staining does occur it may be due to the fuel bed being incorrectly laid. This should be checked prior to contacting a service engineer.
- Care must be taken to prevent any damage being caused to surrounding soft furnishing or decoration; e.g. many embossed vinyl wall coverings may become discoloured if placed too close to the appliance. Combustible material i.e. wall panelling or wallpaper must be removed from behind the fire.
- It is advised that this appliance is serviced annually; as it is more likely to provide trouble-free operation.
- In GB (Great Britain) the fire does not normally require purpose built ventilation, but if for any special reason purpose built ventilation is provided it should be checked periodically to ensure freedom from obstructions.
- In IE (Ireland) permanent ventilation must comply with the current edition of IS813.

Distances from NON-combustible materials:

- The stove can be recessed in a suitable sized non-combustible fireplace but a permanent free air gap of at least 50mm must be left around the sides and top and at least 50 mm at the back of the stove to obtain reasonable heat output and for access to the stove for removal and maintenance.

SECTION TWO Operating the Appliance (Users Instructions)

To light the appliance using the remote handset:

- A. Point the remote control handset in the direction of the appliance and simultaneously press the buttons marked '●' off' and 'standby'. Continue to hold in these two buttons until a 'bleep' is heard (approximately 2-3 sec.) and then release these buttons. The appliance will automatically go through the ignition sequence and the pilot should ignite. Once the pilot is alight the appliance will automatically go to the high setting (approximately 20-25sec). If the ignitor stops sparking and the pilot fails to light, repeat this procedure.
- B. The appliance can be adjusted up or down by pressing the appropriate button  (low setting) or  (high setting). There are 5 heat settings and the fire will give a double bleep when the maximum or minimum heat setting is reached. To switch off the appliance press the OFF ● button or if the appliance is to be switched off for a short period it is recommended that the 'standby' button be used.
- C. The appliance can be switched off without using the handset by unplugging the transformer. When the transformer is removed there will be a delay (up to 3minutes) after which double bleeps may be heard and shortly after the appliance will extinguish. Ensure that the transformer is reconnected once the fire has been extinguished. The appliance cannot be operated without the use of the handset. If the fire fails to light or extinguishes for any reason, it will be necessary to re-set the fire. This can be done by pressing the off ● button then following the normal lighting procedure.

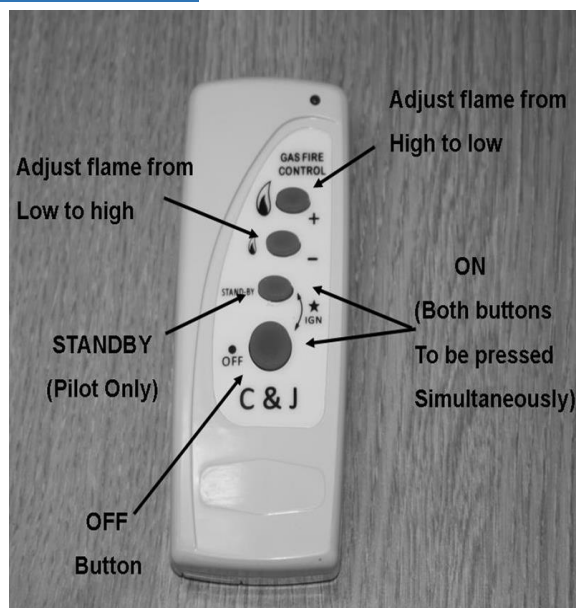

Note: if repeated delayed ignition is experienced during start-up it is recommended that the appliance is checked by a gas safe engineer

NOTE: If the fire is extinguished for any reason wait 3 minutes before relighting.

Low Battery Indication (Handset)

If while pressing any of the buttons on the remote handset the low battery indicator lamp either stops flashing or appreciably slows then the battery should be changed.

To Replace Batteries in Handset (AAA 1.5 v lr3 x2)

Remove the cover from the rear of the handset and fit replacement batteries, taking note of the orientation.

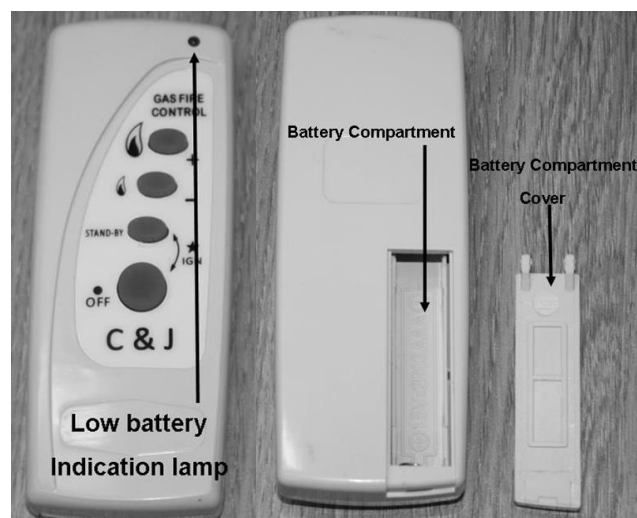

SECTION THREE Cleaning (Users Instructions)

Warning: -

Before you clean any part of the appliance ensures that the appliance is turned off and cold.

Cleaning: Black Painted Surfaces

- These surfaces should be dusted regularly and any marks removed with a soft cloth.
- Abrasive or chemical cleaner should **never** be used.
-

Glass Cleaning

*From time to time it will be necessary to clean the glass panel of your PV5W Gas Stove. We recommend you use a Ceramic hob cleaner these are available for all leading super markets: - i.e. **ASDA, TESCO, SAINSBURY'S** Etc.*

Brands of hob cleaning we have tested and found suitable are - **HOB BRITE & VITRO CLEAN.**

- Ensure the fire as been turned OFF for at least four hours to ensure it is cool.
- Lift the Top Plate up and twist it sideways so it sits on the body of the stove.
- Pull forward on the door to disengage the lower magnets and lift the door upwards to remove.
- Remove the 2 off M4 fixing nuts from the glass fixing bracket located at the top of the glass panel.
- Remove the top fixing bracket why supporting the glass panel.
- Lift the glass panel from within the bottom support bracket.
- Lay some old newspaper under the area you are working on when the door is open.
- Follow the instructions on the Hob Cleaner Bottle.
- On stubborn stains (where the appliance as been used for a long period without glass panel being cleaned), use a new Brillo Pad well wetted with the Hob cleaner applied directly to it.
- Ensure all the residues of the cleaner are removed with a damp cloth and the glass panel is completely dry before closing/rehanging the door and refastening the door to the stove.

Important: - The appliance must not be used if the glass panel is missing or damaged.

Note: - The glass may discolour quickly when first installed, and it should be cleaned. This is due to the burning off process of the refractory shapes.

SECTION FOUR Fuel Bed Cleaning and Layout (Users Instructions)

Warning: -

- Before you clean any part of the appliance ensures that the appliance is turned off and cold.
- Use only the fuel bed components provided and no additional parts must added.
- Incorrect positioning of the fuel bed components could result in the staining of the glass panel.

Important: - Refer to the 'Health & Safety Notice located on page 5 of this booklet before cleaning or replacing any refractory material.

- The fuel bed components are delicate and they should be handled with great care.
- The loose Log shapes may be removed for cleaning. They can be brushed very gently with a soft brush to remove dust or any deposits.
- A vacuum cleaner may only be used after the loose Log shapes and vermiculite has been removed.

CARE SHOULD BE TAKEN TO AVOID DAMAGE TO THE LOG SHAPES AS THESE ARE A DELICATE SURFACE AND SHOULD **NOT** BE WIPED OR RUBBED.

It is important that all the Log Fuel Bed shapes are positioned as shown in these instructions.

Log Fuel Bed Layout

Place The first shape on top of the locating pins as shown.





Spread a thin layer of vermiculite over the burner plaque taking great care around the pilot area.





Tease out half of the emberglow to make a very loose network of fibre and place in the spaces between the shapes and above the burner ports as highlighted

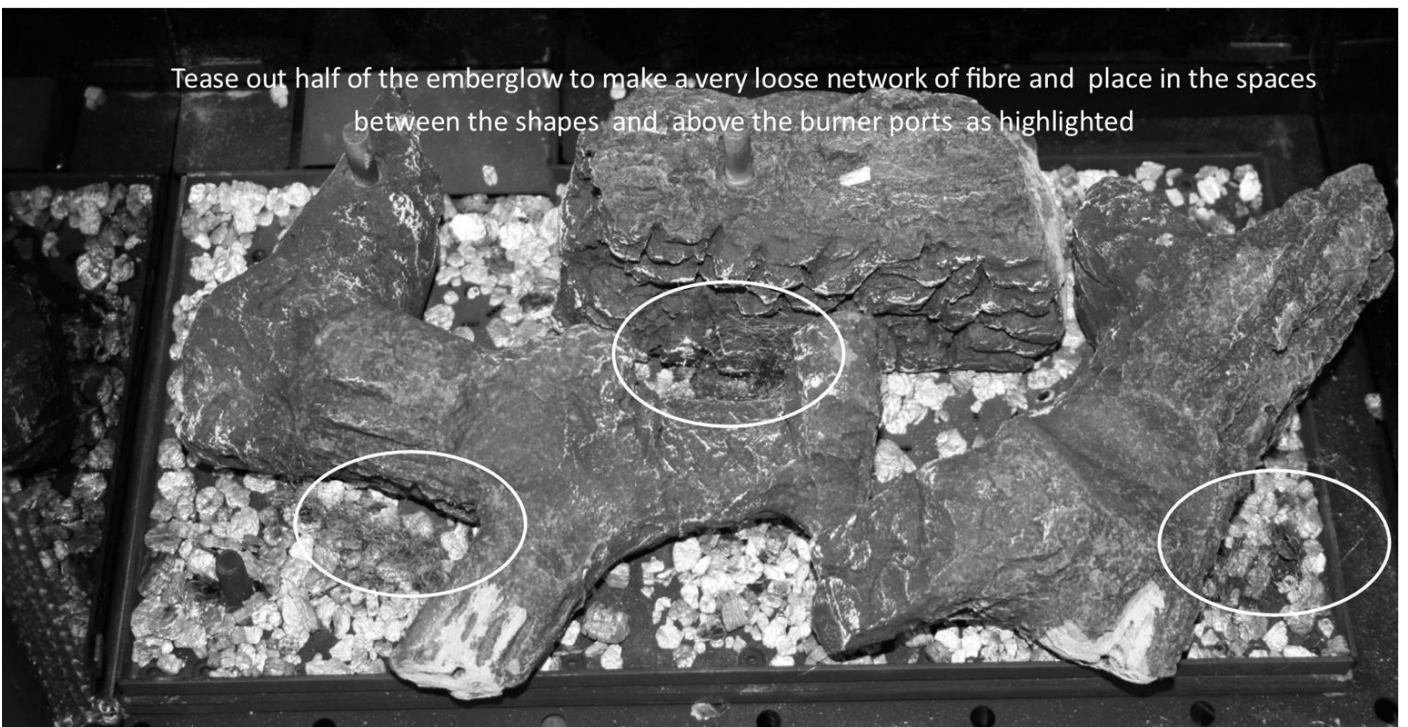

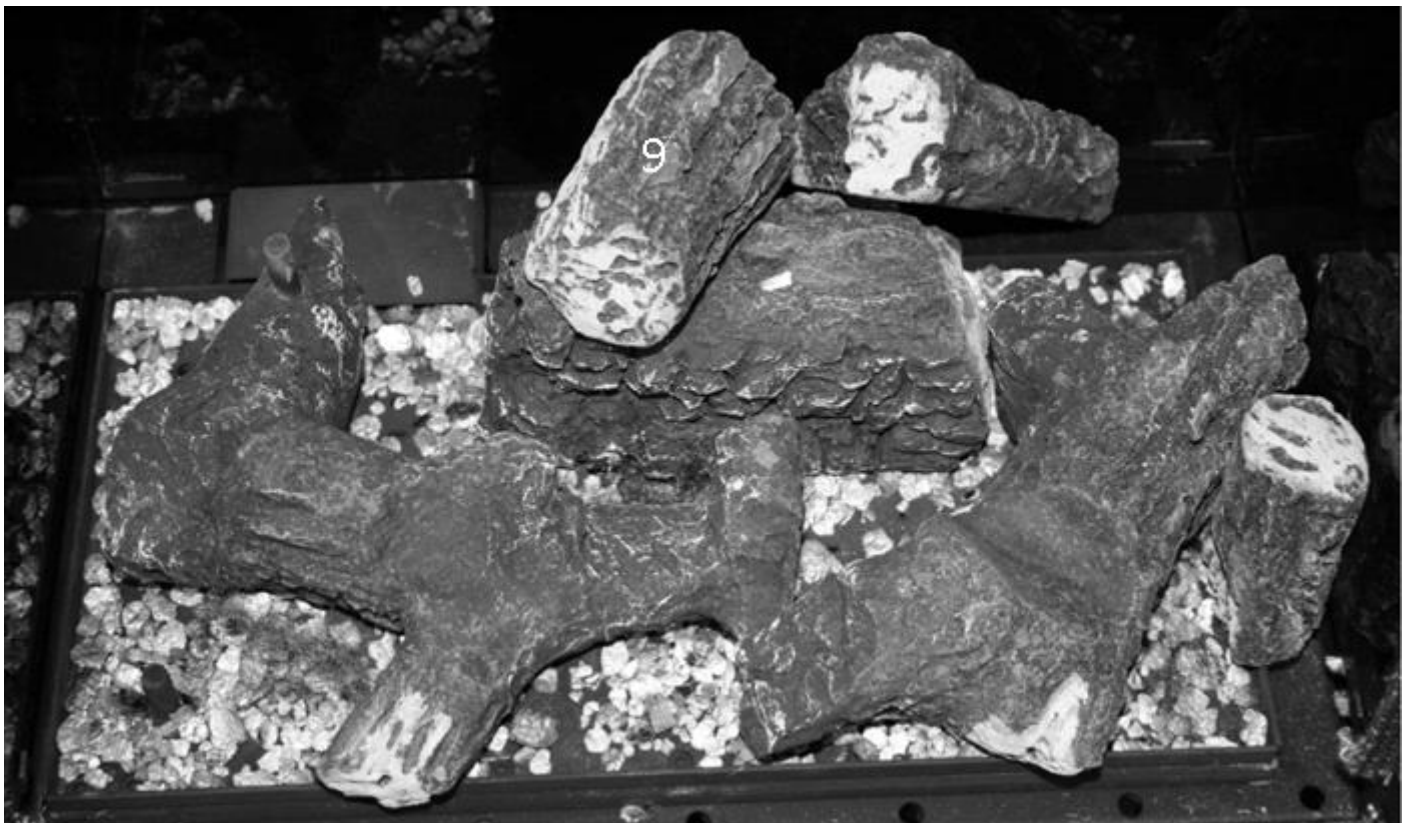
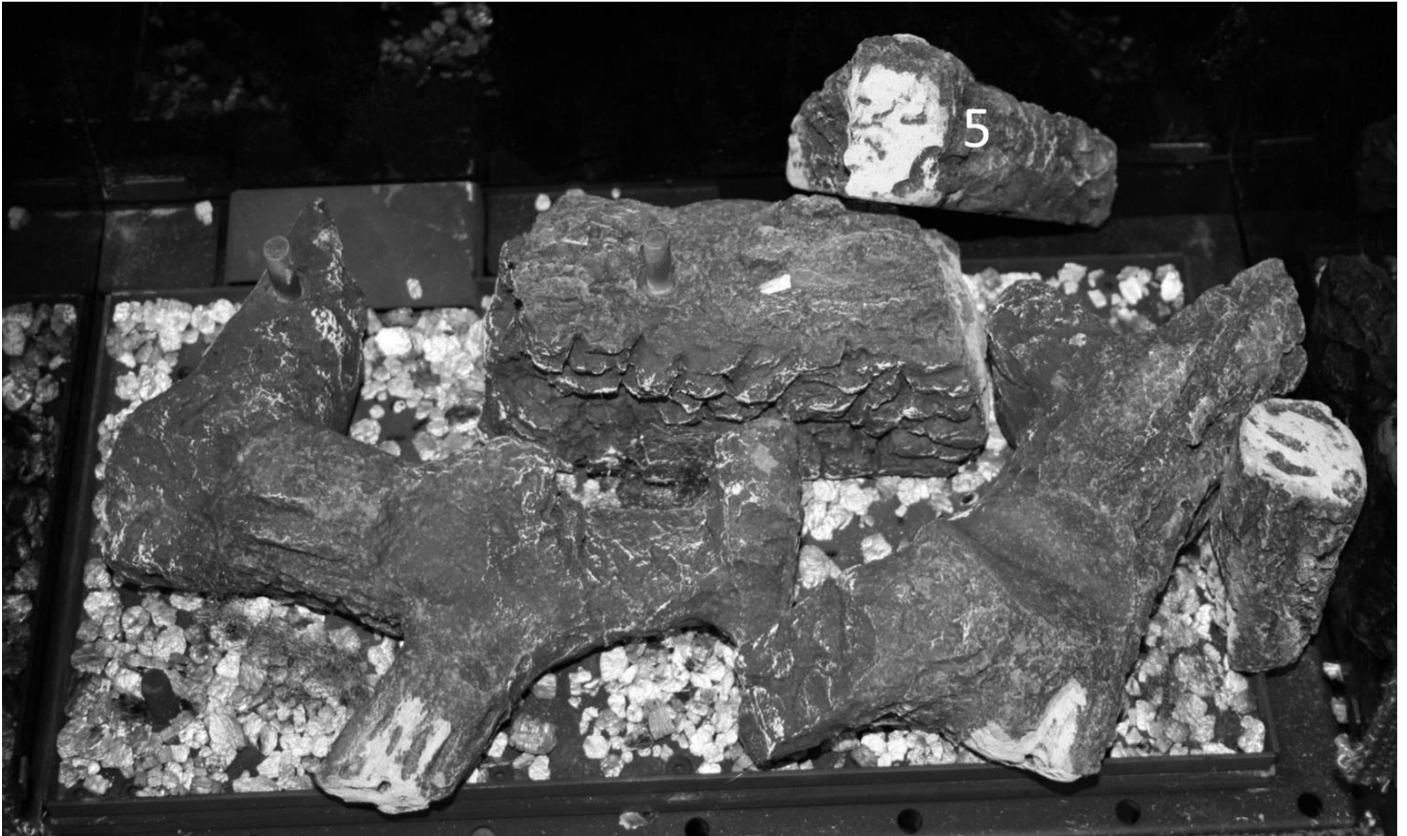

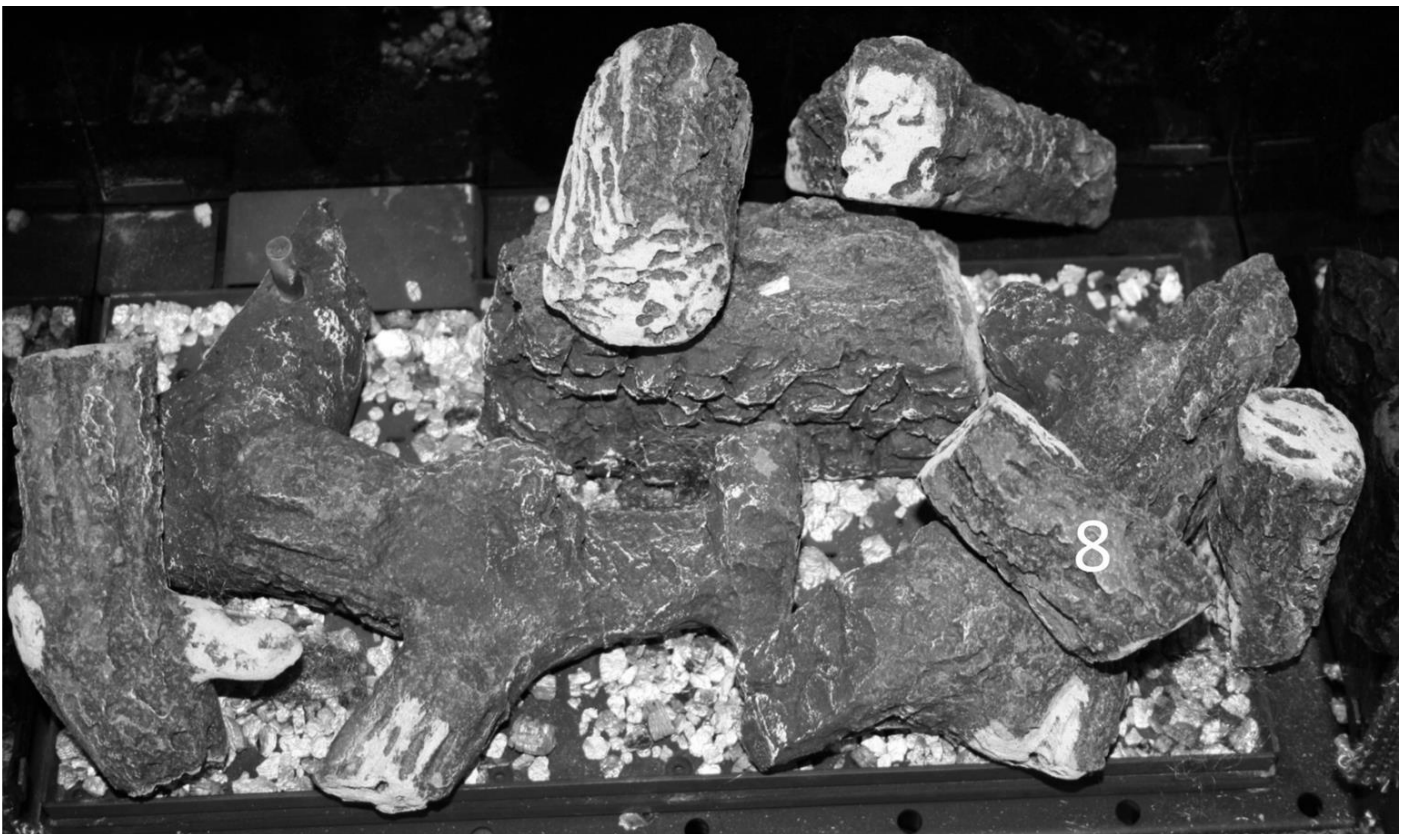
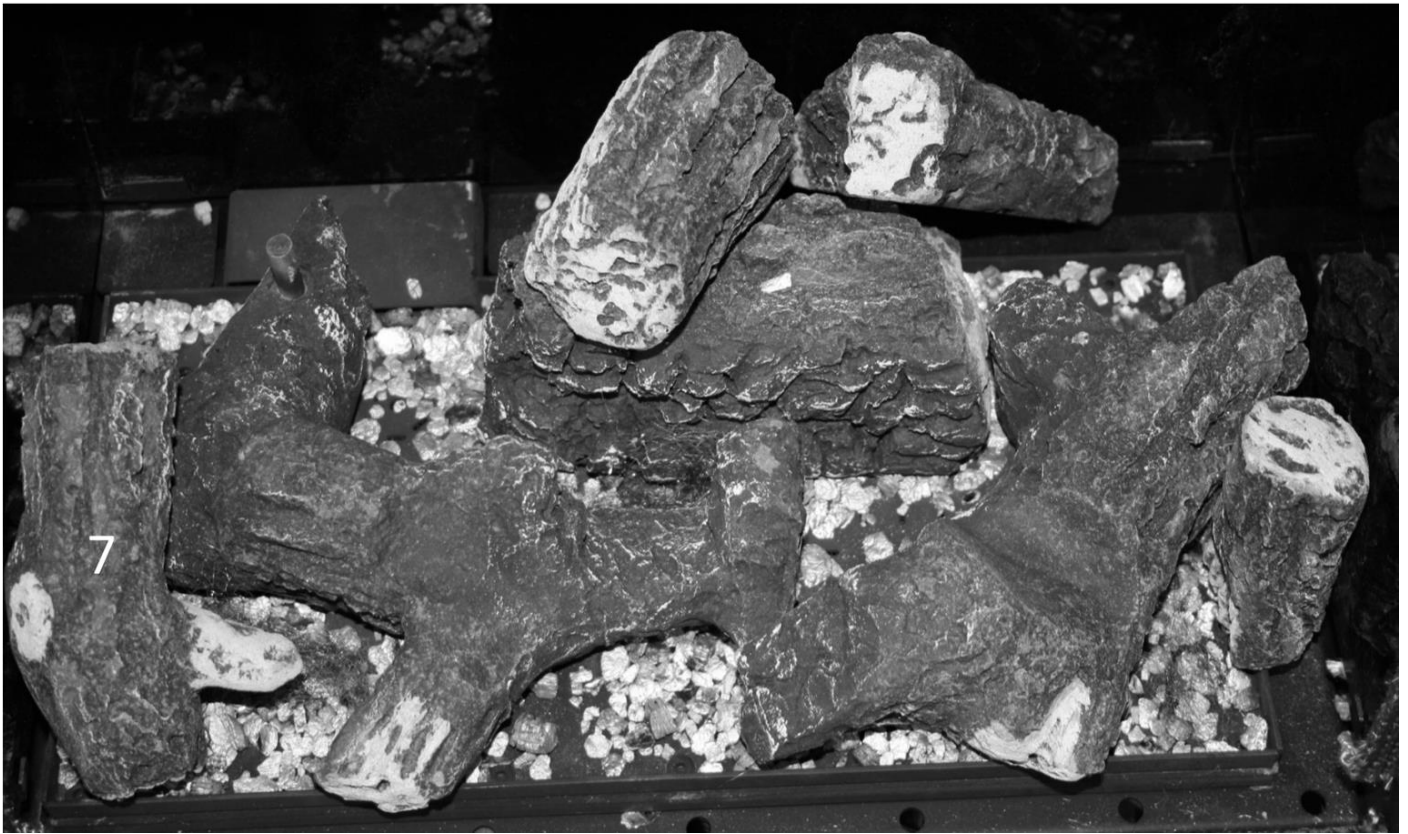





Please note the number 12 shape is only included with the Edge 3s fuel bed. Failure to fit this shape correct could result in sooting deposits on the side glass window. The shape should be place directly on the burner tray alongside the pilot shield.

Large log fuel bed lay out Natural Gas Only

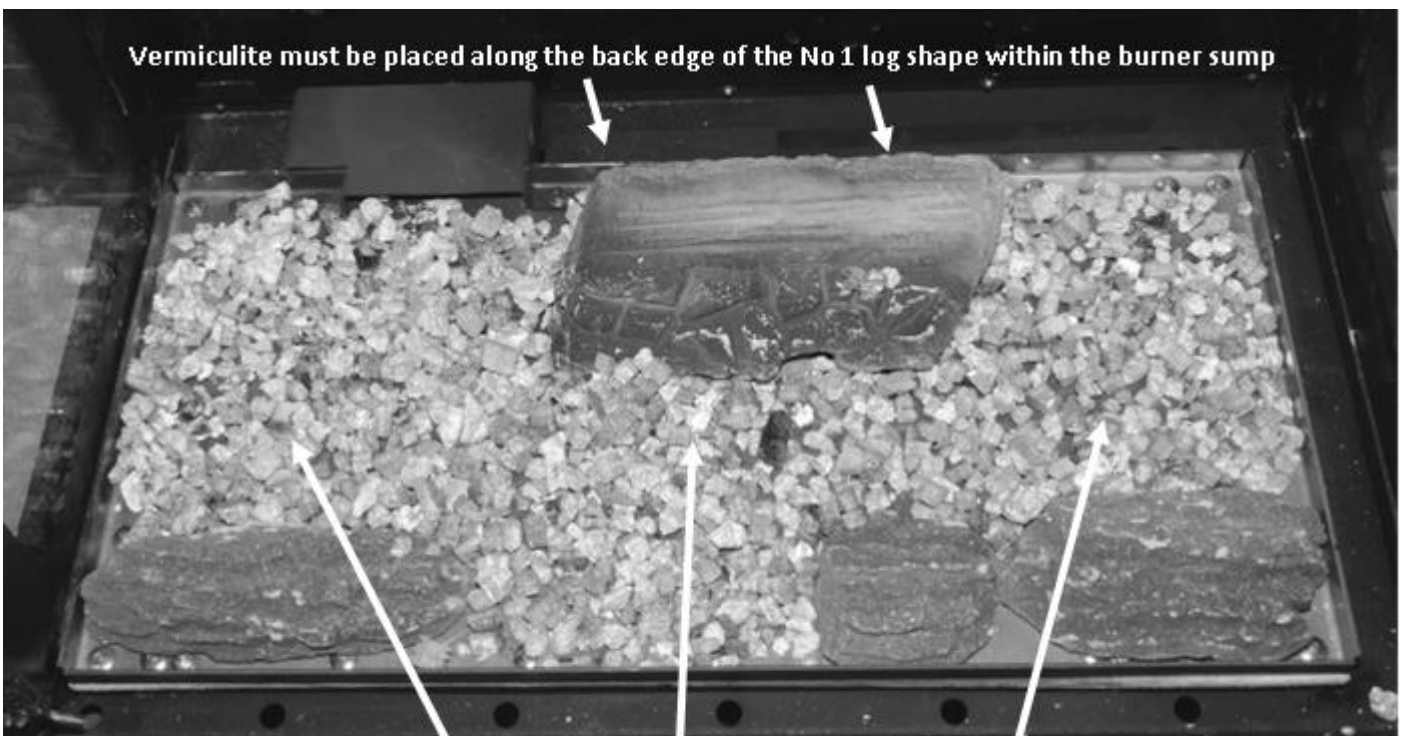
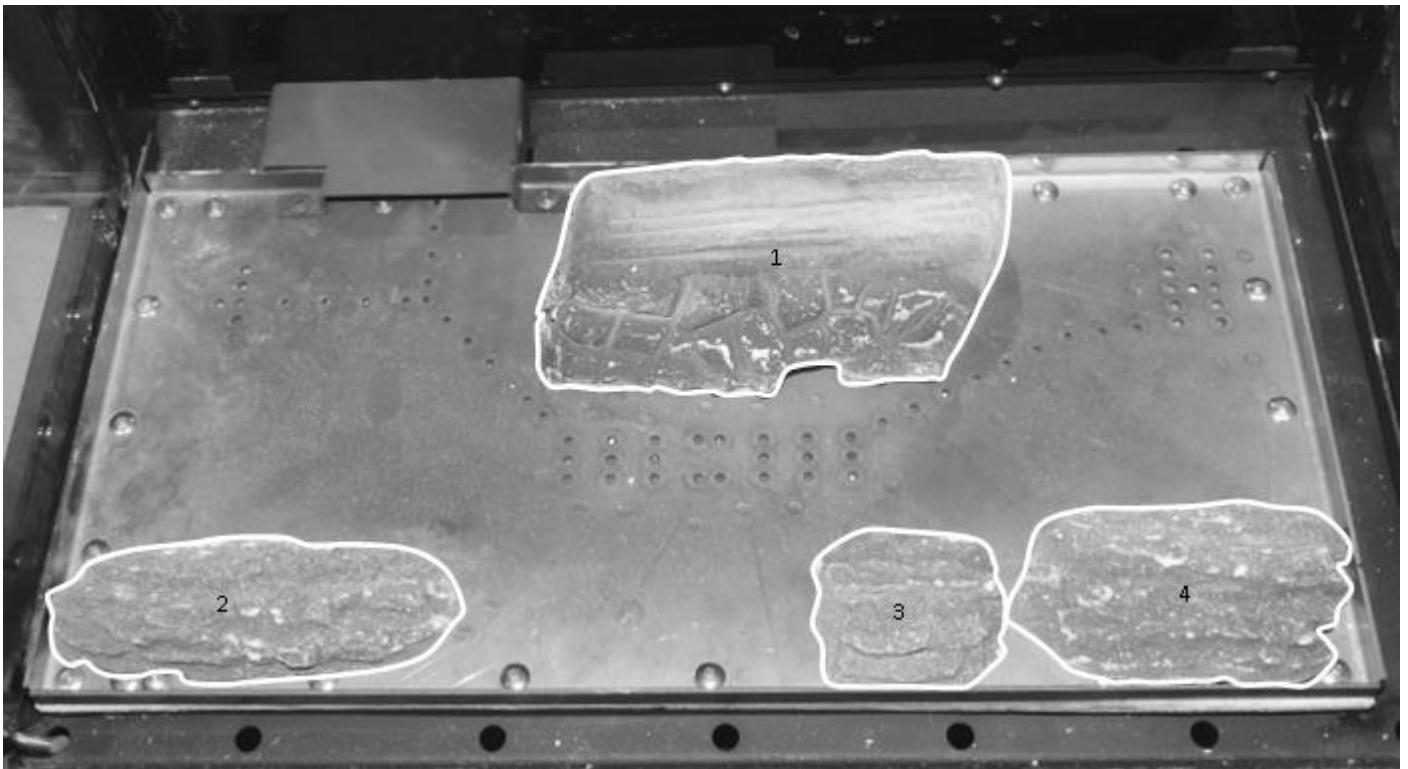

Place a even amount of vermiculite across the complete area of the burner sump.

DO NOT PLACE NEAR THE PILOT AREA

Tease out the Embaglow to form a very loose, very light network and place in the area shown below

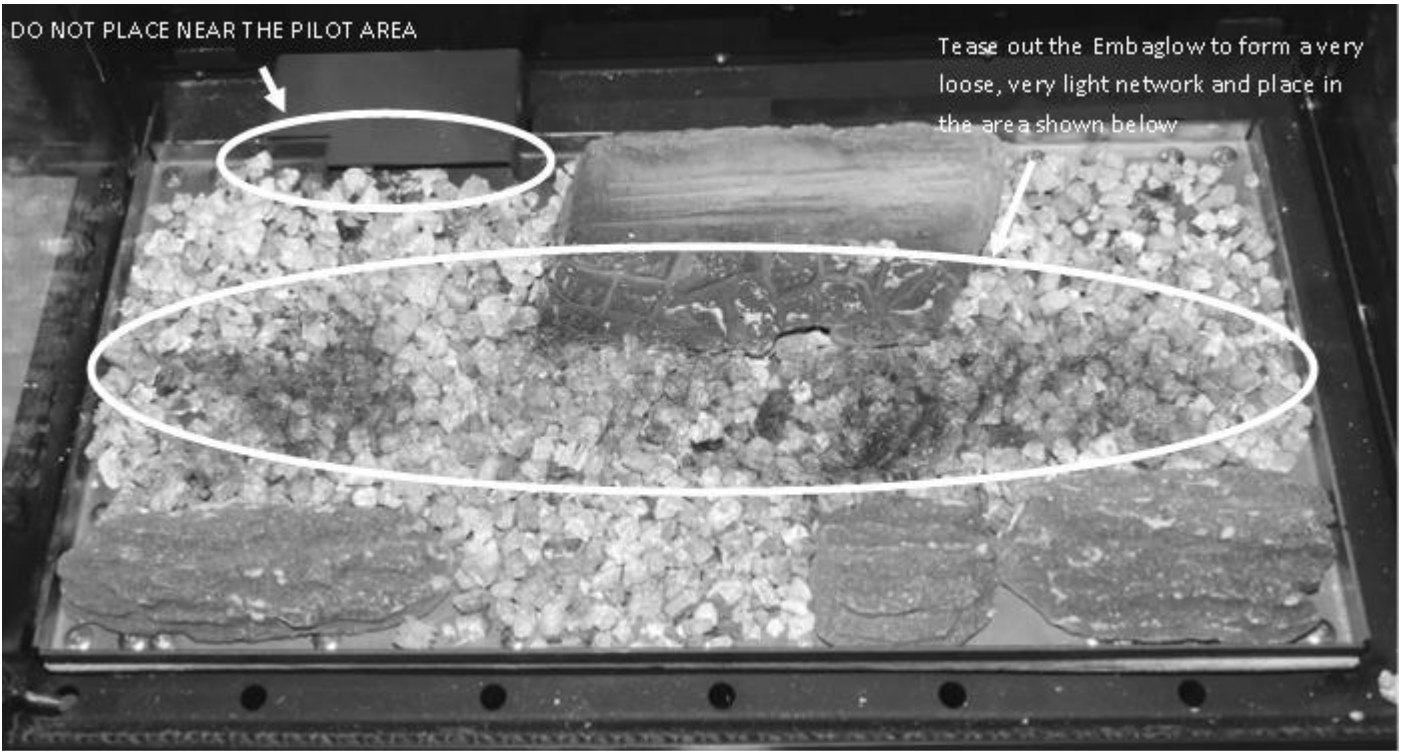

Locate the No 5 Shape directly upon the burner pilot shield and within the gap between the burner and the rear lining

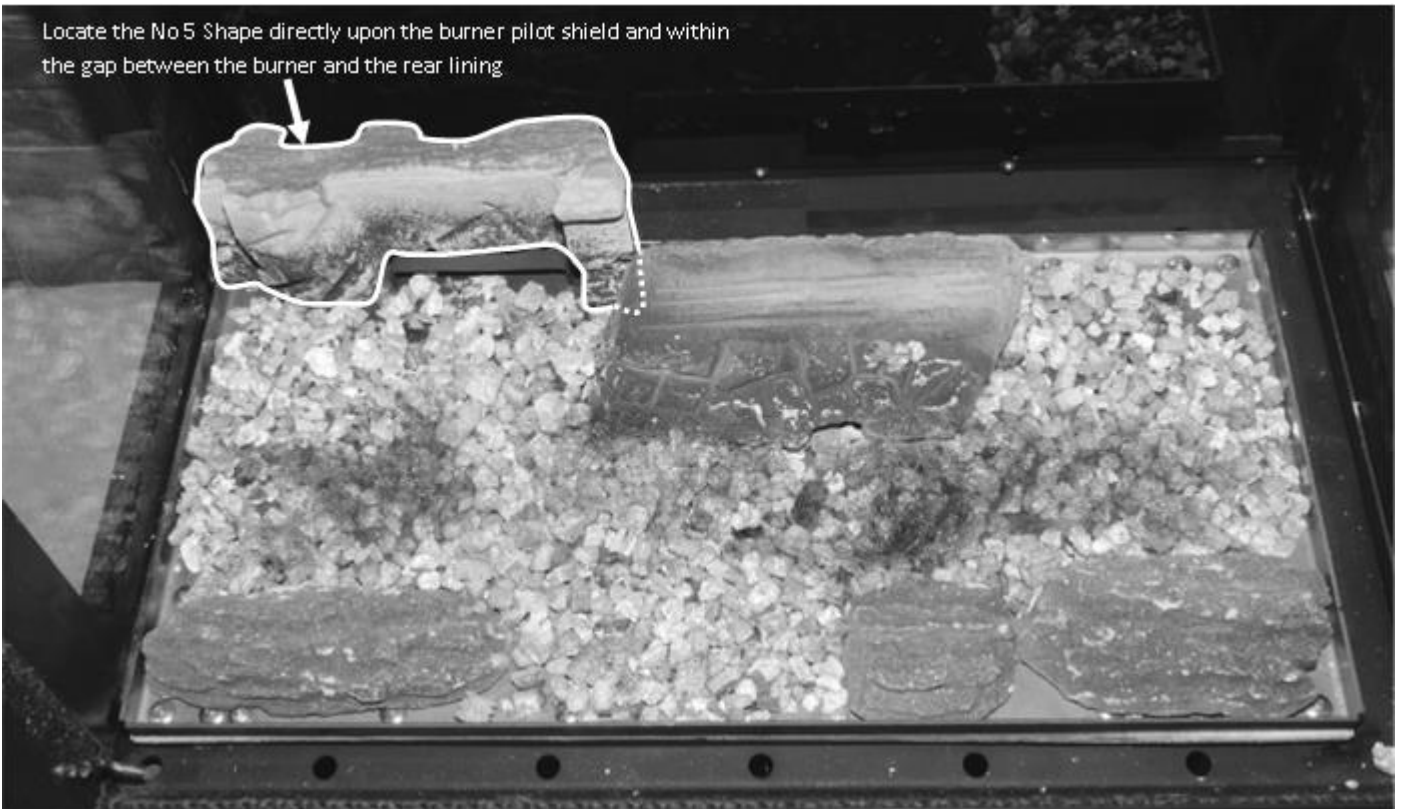

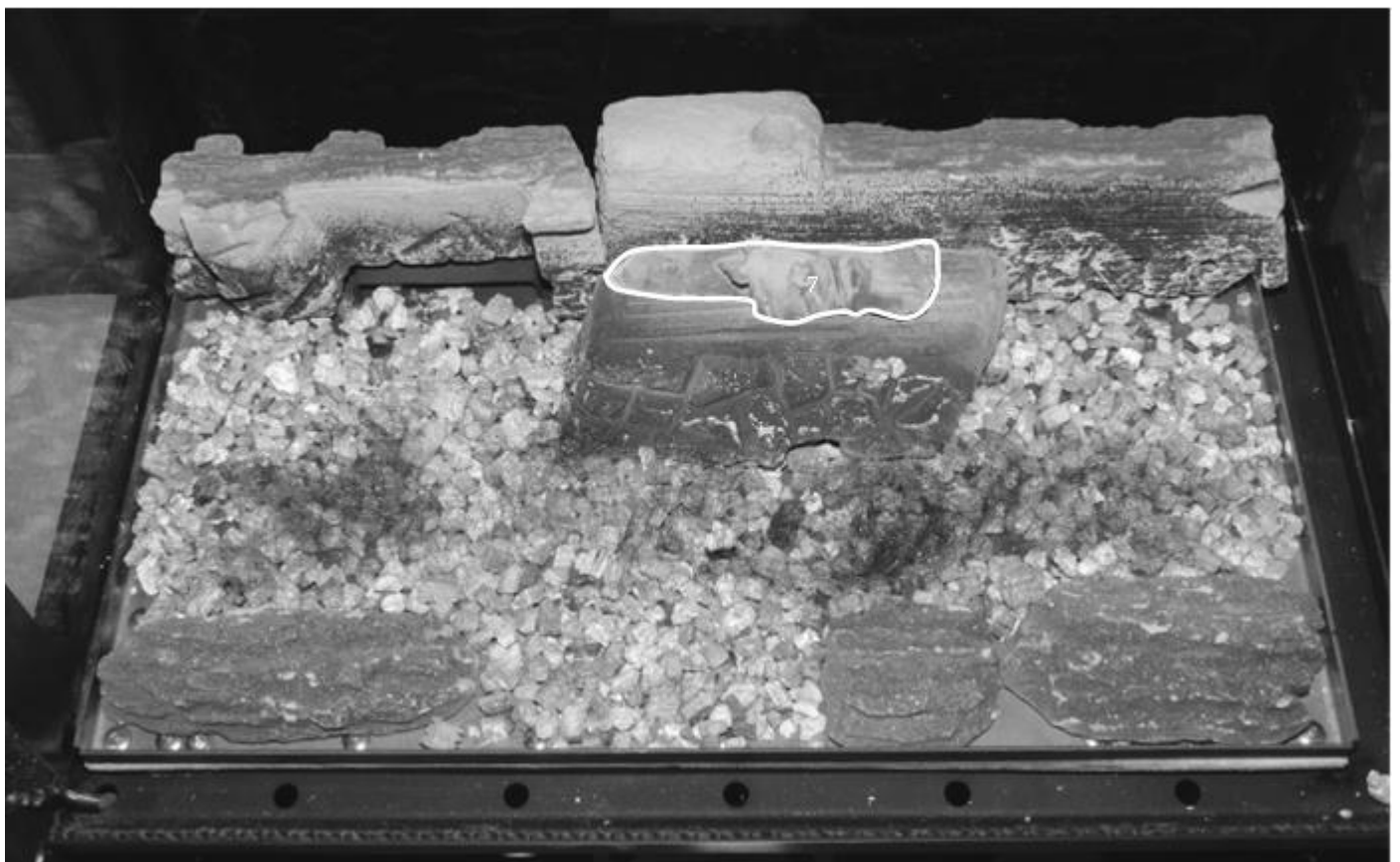
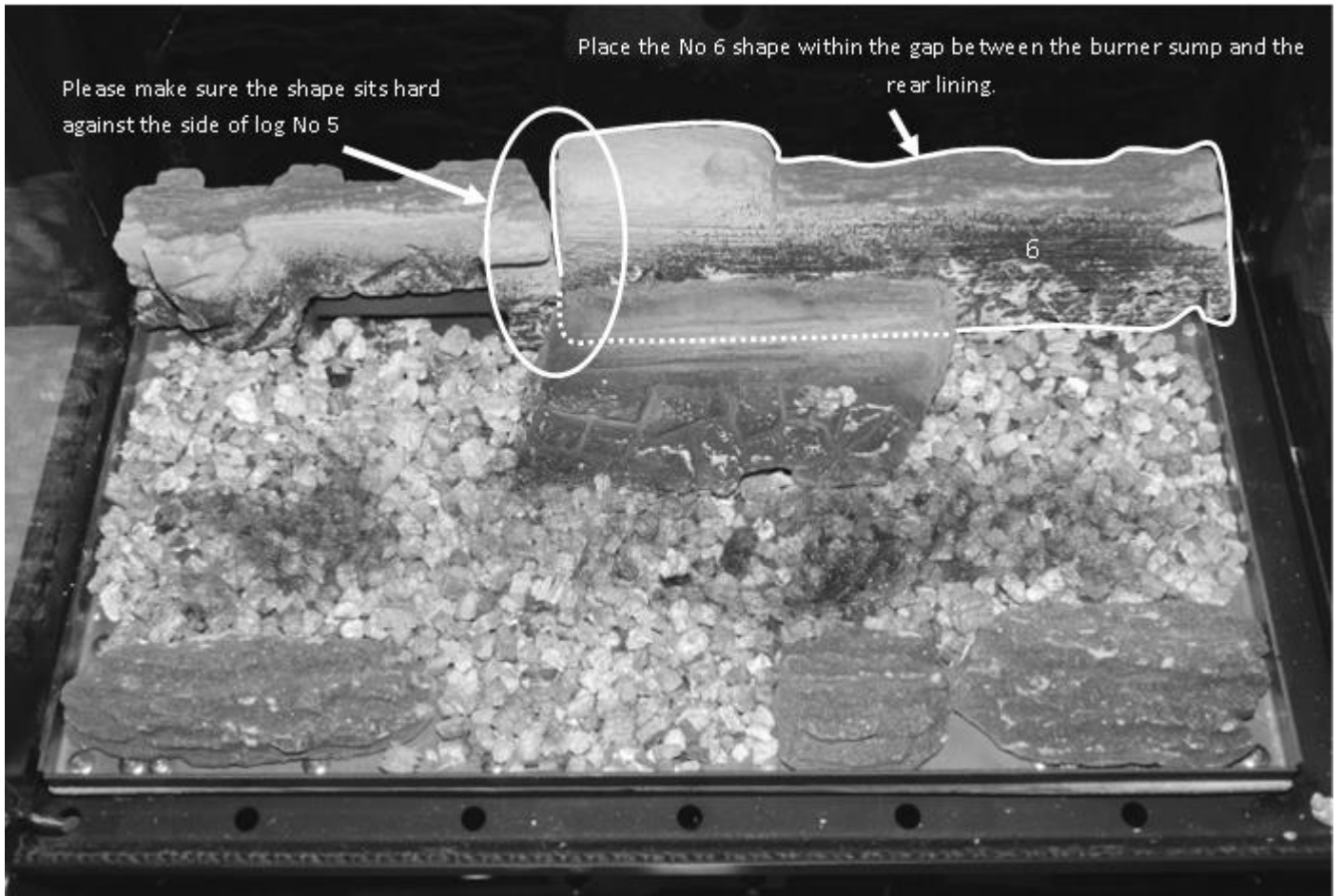



The No 8 shapes need to be position as shown with the flat face hard against the side glass panel and the No 5 log

Please note:- failure to position the shape correct can result in marking upon the side glass panel



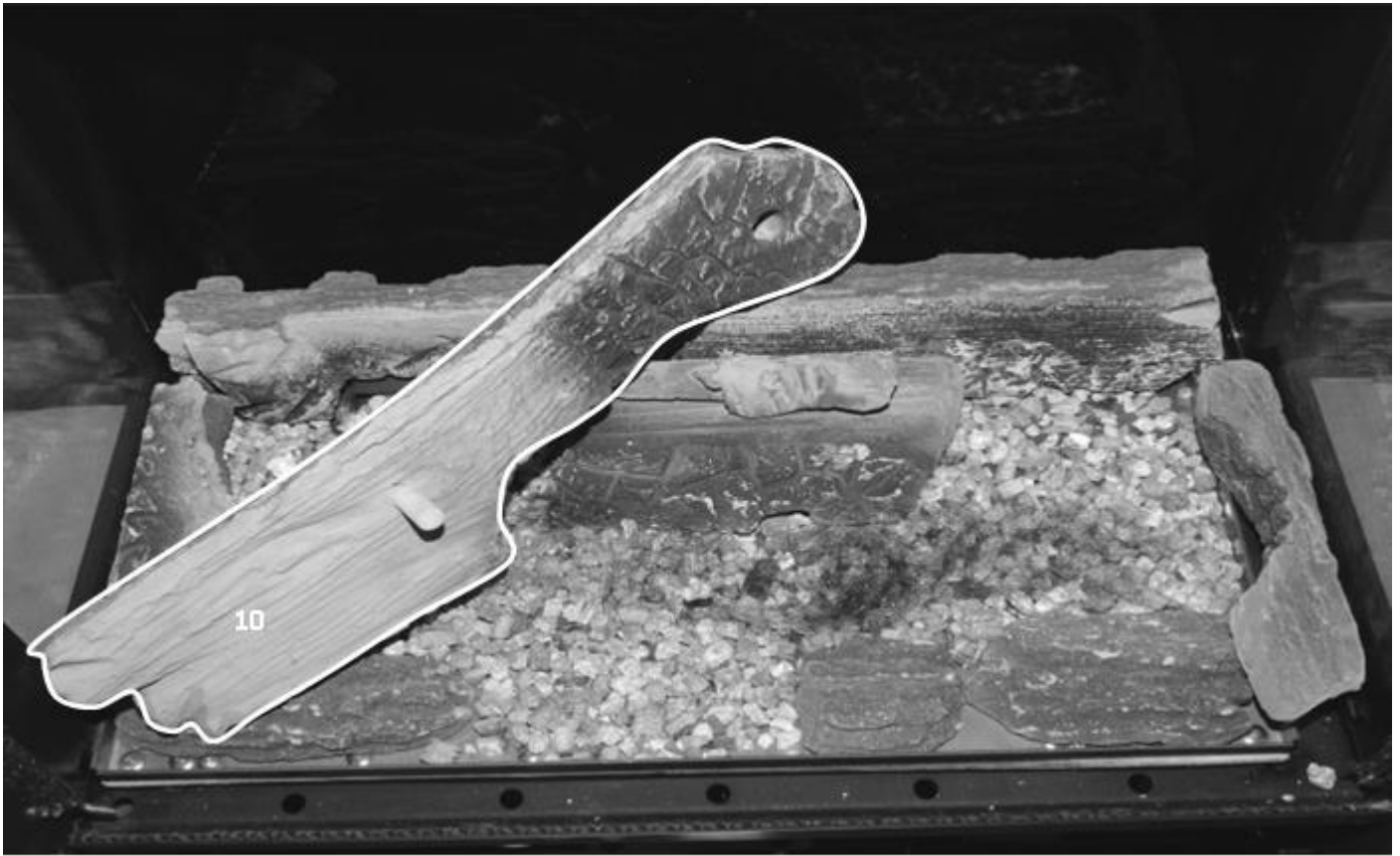

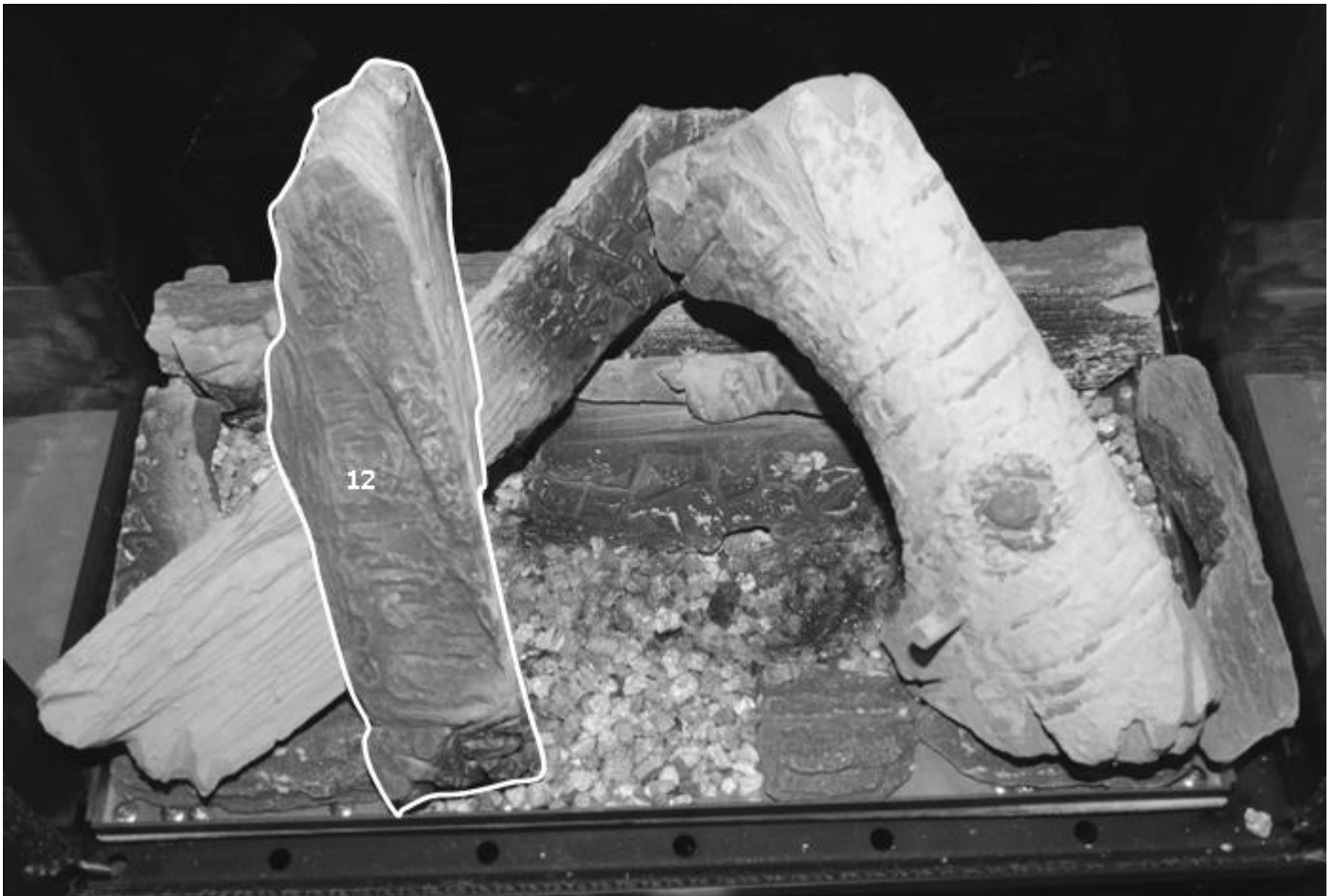

SECTION FIVE General Points (Users Instructions)

Like all appliances incorporating an aerated burner a low frequency noise may be heard, particularly on the low setting, this is quite normal and does not affect the operation of the appliance.

It is advised that a competent person service the Paragon Edge fire annually. The fire is more likely to provide trouble-free operation.

Dulling and slight discoloration inside the firebox will occur adding to the realism of the appliance. This is normal.

It is important that: -

- The chimney or flue is checked annually to ensure clearance of combustion products.
- Any debris from the chimney or flue should be removed. The fire should be allowed to cool before it is removed.
- The fire must not be used if the glass panel is missing or damaged.
- The data badge is located on the rear of the door.

The only user removable parts are: -

- Refractory Fire bed Components.
- Glass panel.

SECTION SIX Appliance Data (Installation Instructions)

Please note the Edge 3s is available Nat Gas only

	NATURAL GAS	PROPANE GAS
Gas Type:.....	CATEGORY I _{2H}	CATEGORY I _{3P}
Gas Pressure:.....	20 mbar +/- 1.0mbar	37 mbar +/- 1.0mbar
Pressure Test Point Location:.....	Gas inlet elbow	
Gas Input:.....	5.3 kW Gross (Max)	5.0 kW Gross (Max)
	0.530 m ³ /h Gross (Max)	0.500 m ³ /h Gross (Max)
	3.0 kW Gross (Min)	3.3 kW Gross (Min)
	0.300 m ³ /h Gross (Min)	0.330 m ³ /h Gross (Min)
Injector:.....	Mk 360 A	Mk 116
Oxy pilot:.....	2900 NGR	LPG 9264
Gas Connection:.....	8mm compression: semi-rigid or rigid	
NOX Class.....	5	5

Data Badge located on the inside of the door.

Appliance Dimensions :-

PARAGON Edge & Edge 3s STOVE DIMENTIONS

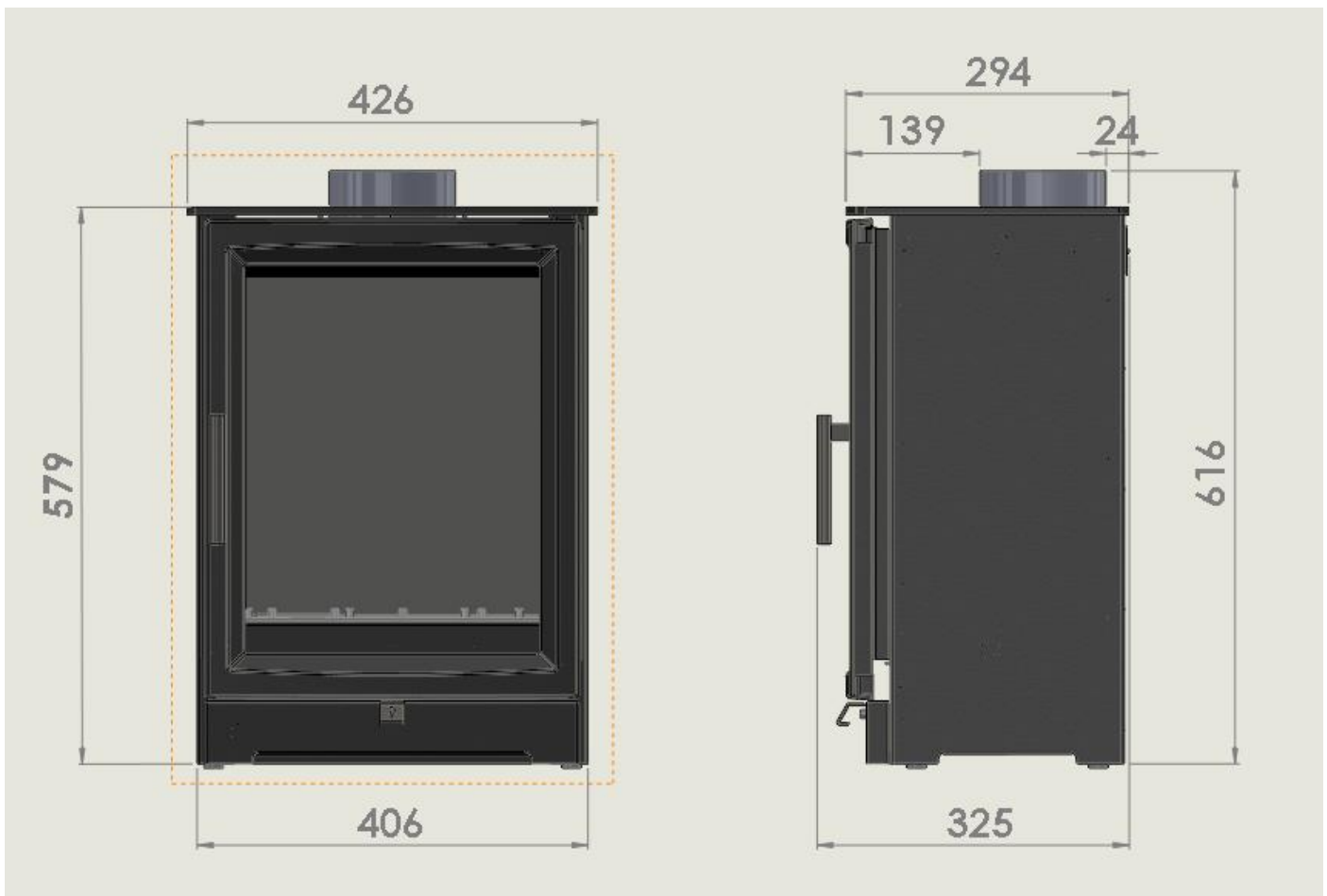

Data Badge located on the rear of the door of the Stove.

NOTE: The efficiency of this appliance has been measured as specified in BS EN 613:2001 and the result is 74.1% for Natural Gas and 71.4% for LPG Propane. The gross calorific value of the fuel has been used for this efficiency calculation. GasTec have certified the test data from which it has been calculated. The efficiency value may be used in the UK Government's Standard Assessment Procedure (SAP) for energy rating of dwellings.

When unpacking the appliance please check the following items are included:

- Fuel Bed
- Owner manual
- Handset

SECTION SEVEN Regulations and Warnings (Installation Instructions)

- This appliance must only be installed in Great Britain or Ireland.
- The appliance is suitable for use on natural gas and propane
- **GB (Great Britain)** This fire does not normally require purpose built ventilation.
- **IE (Ireland)** Permanent ventilation must comply with the current edition of IS813.
- **In GB, (Great Britain)**
- **This appliance is intended for use on a gas installation with a governed meter.**

It is the law that all gas appliances must be installed by a competent person; i.e. a GAS SAFE registered installer, in accordance with the Current Gas Safety (Installation And Use) Regulations (as amended), all relevant parts of the local and national building regulations and all relevant recommendations of the following British Standards. Failure to do so could lead to prosecution.

The following are relevant codes of practice and British Standards: -

B.S. 5871

B.S. 5440 PART 1 & PART 2

B.S. 6891

This appliance must be installed to current versions of the above standards and include any relevant amendments to:-

The Building Regulations Issued By The Department Of The Environment.

The Building Standards (Scotland) (Consolidated) Regulations Issued By The Scottish Development Office.

- **IN IE, (Ireland)**

The appliance must be installed by a competent person and installed in accordance with the current edition of I.S.813 Domestic Gas Installation, the current building regulations, and the current ETCl rules for electrical installation, if appropriate.

- Prior to the installation ensure that the local distribution conditions (identification of type of gas and pressure) and adjustment of the appliance are compatible. Natural gas (G20 @ 20mbr)

WARNINGS

- The glass front of the fire act as a dress guard, conforming to BS 1945 (1971) and satisfies the heating appliance regulations (1991) However, a guard conforming to BS6539 (1984) must be used to protect young children, the elderly or infirm.
- **This appliance incorporates a safety device in the form of an Oxygen depletion system. IT MUST NOT BE ADJUSTED OR PUT OUT OF OPERATION! THIS IS A NON-SERVICABLE ITEM AND MUST BE EXCHANGED AS A COMPLETE ASSEMBLY; USING ONLY THE ORIGINAL MANUFACTURER'S PART.**
- A non-combustible hearth must be provided to comply with the building regulations, or a suitable proprietary fire surround with a 150°C minimum rating.
- During initial firing, an odour may be evident. This is the starch binder used during the manufacture of the fibre components of the fire, and there are **no harmful** effects produced.
- Care must be taken to prevent any damage being caused to surrounding soft furnishing or decoration; e.g. many embossed vinyl wall coverings may become discoloured if placed too close to the appliance.

Note: Dampers or register plates must not restrict any of the above flues. The flue must only service a single appliance and not have any branches or traps, which may impede the natural draught. If a terminal is fitted it must be suitable for the purpose.

Note: A non-combustible hearth must be provided beneath the appliance and must extend outwards by 50mm all around the appliance base. The hearth must be level and have a minimum thickness of 12mm and must have a clearly defined edge (change of level) to discourage placing of any combustible materials on or partially over it.

SECTION EIGHT Siting the Appliance (Installation Instructions)

Optional stand

The Edge CF product can be fitted stove body only or with one of the following options.

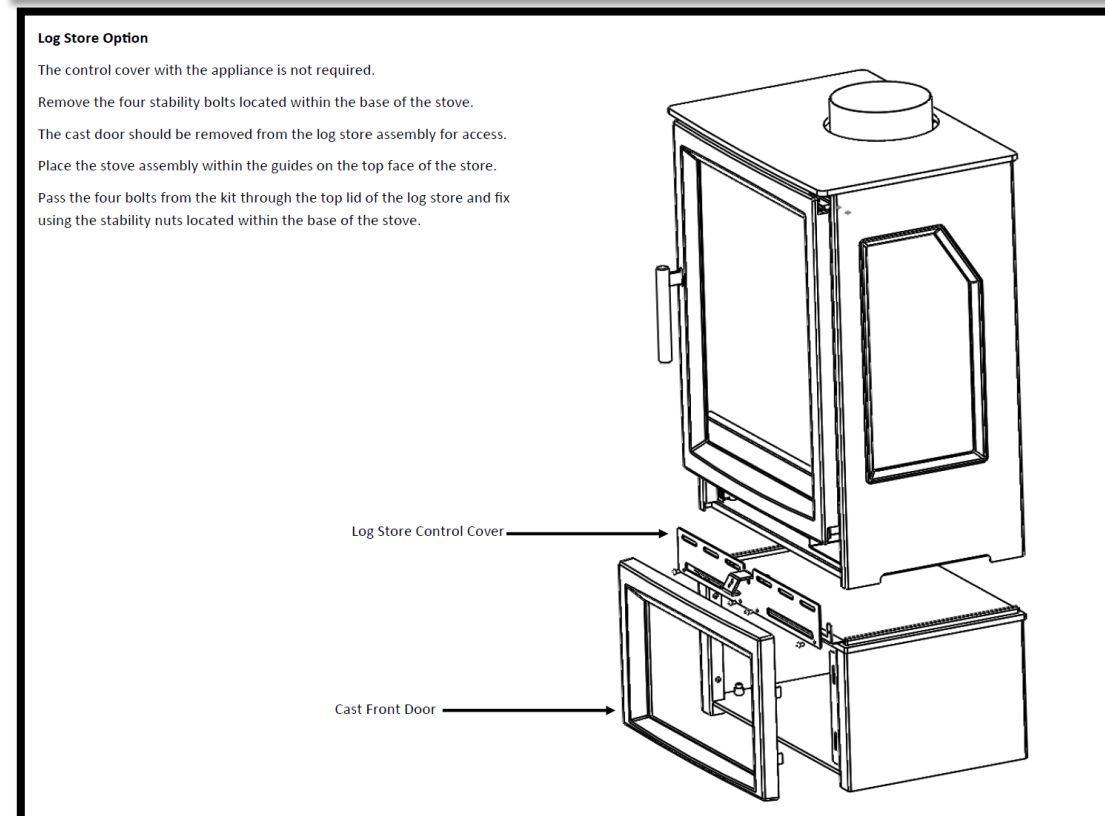
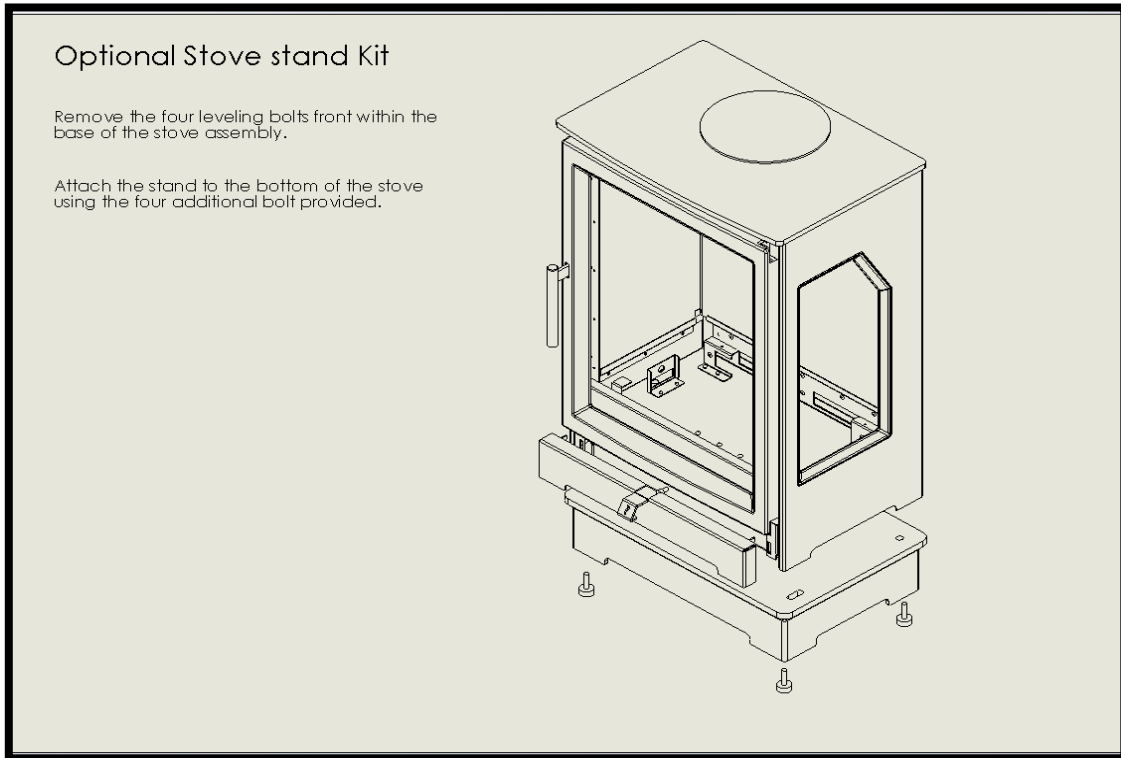

Please note suitable wall plugs fixings and screws must be used to support the weight of both mounting bracket / stoves. The wall mounting option is not compatible with the rear exit on this model.

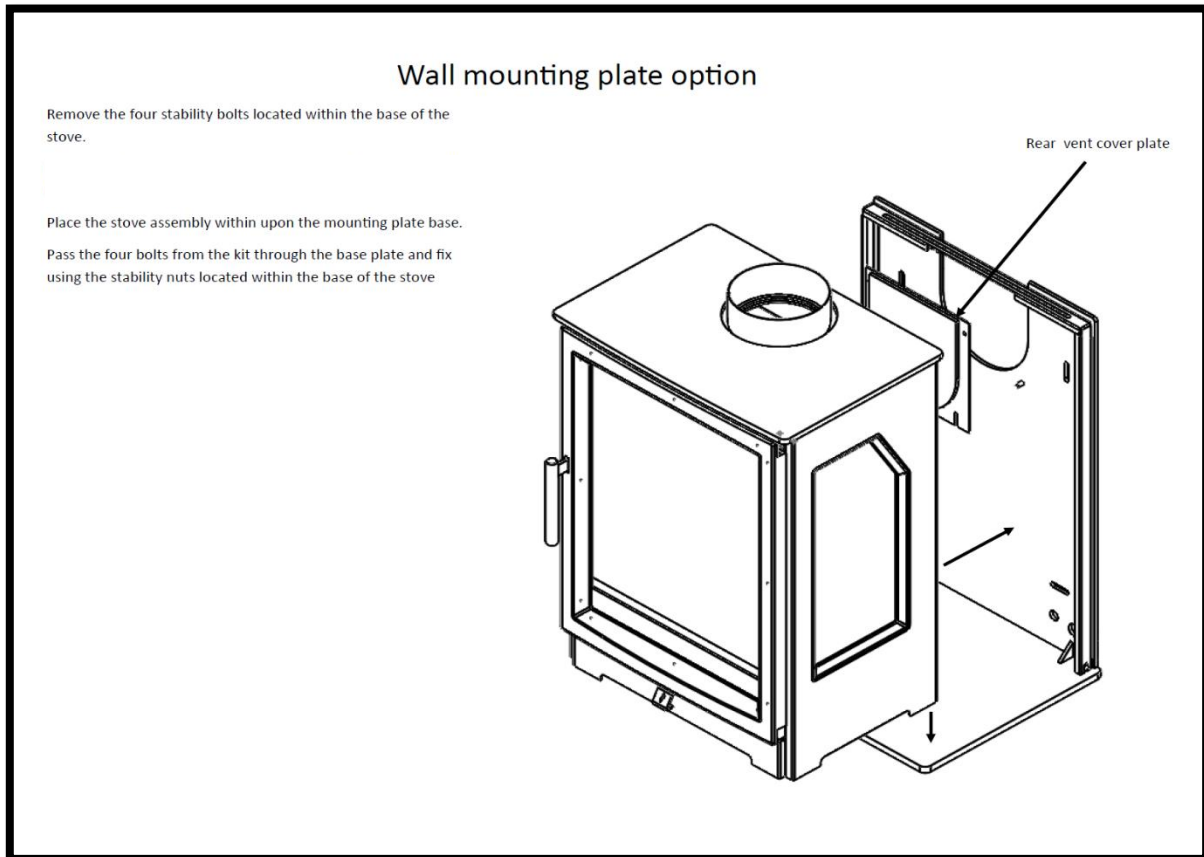

Class 1 Conventional Flue.

The chimney must have a minimum effective height of at least 3 metres. Any permanent flue restriction or variable dampers are to be removed or locked fully open. The chimney should be swept prior to installation if it has previously been used with solid fuel. This is not necessary if the flue has previously been used with a gas appliance or if it is a new installation.

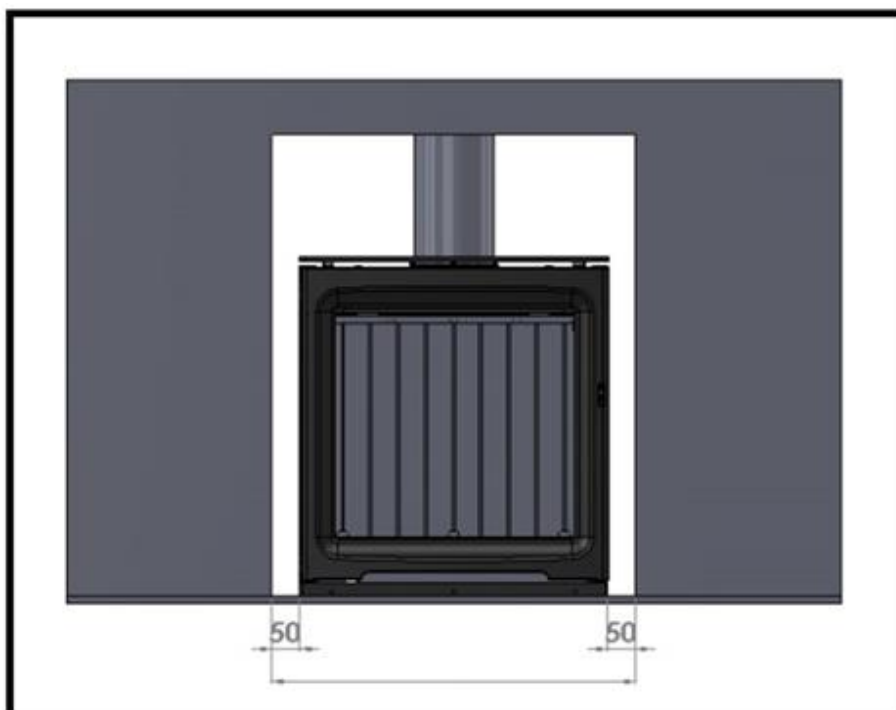

Flue Spigot

The Circular Spigot and Gasket are packaged separately in the appliance for transportation, and must be fitted when connected to a Conventional Flue.

Hearth Requirements

This fire must stand on a non-combustible hearth that is at least 12mm thick and project 50mm minimum from the base of the fire in all directions.

Fireplace Opening (When using the rear vent closure plate).

The builders opening must be fully sealed using with the closure plate. The width of the opening must be between minimum of 290mm to a maximum of 335 mm. The height of the opening must be between a minimum of 550mm to a maximum of 560mm.

Clearances required when installing into a Inglenook opening

Top Exit: Using Register Plate (Not Provided)

The appliance is provided with the gather outlet allowing for vertical flue installation.

Flue pipe used for this type of installation must be 125mm (5 inches) minimum diameter and 3 metres minimum effective height.

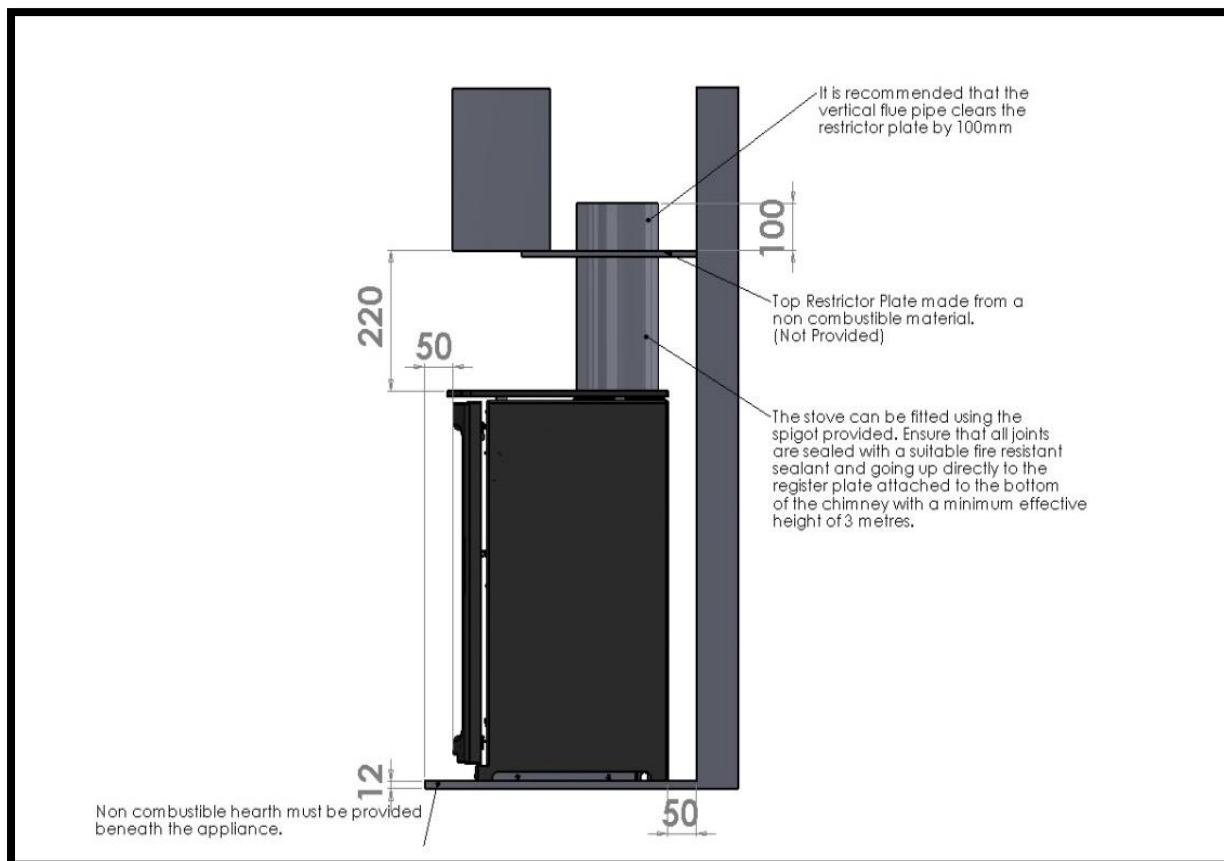

Rear Exit: Using optional Edge Gas Stove rear vent Kit (Part Number 8112)

Precast Flue (Please note the Spigot restrictor plate must be removed)

The appliance can be installed to a precast concrete or clay flue block system conforming to BS1289 or BS EN 1806. The appliance is suitable for installation conforming to older versions of BS1289. The cross-sectional area must not be less than 13,000mm². The chimney vertical height must not be less than 3m and be correctly terminated.

To achieve the rear exit option, the appliance gather hood will need to be removed. The outlet spigot from with the rear vent kit will need to be attached to the firebox assembly and engaged within the closure plate.

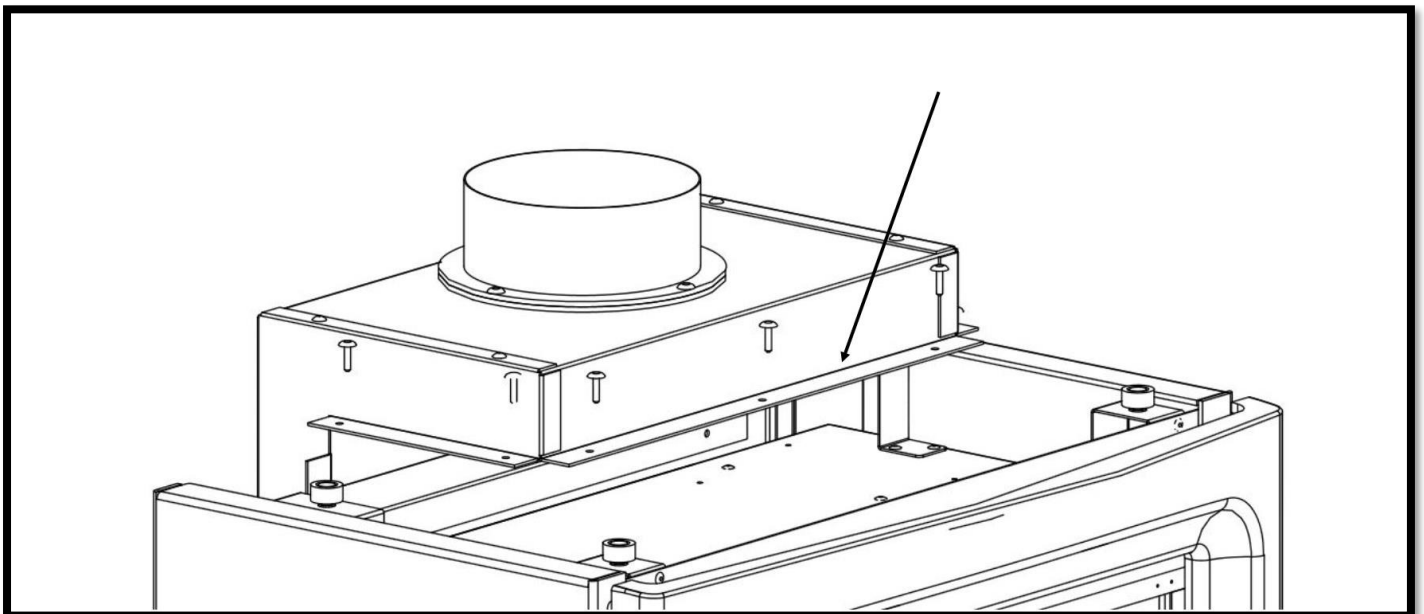
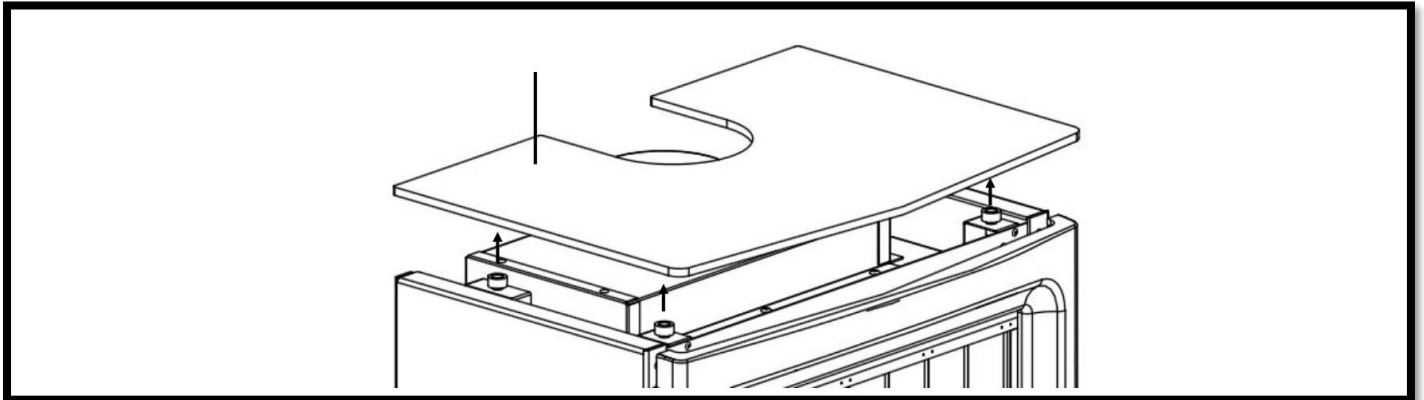

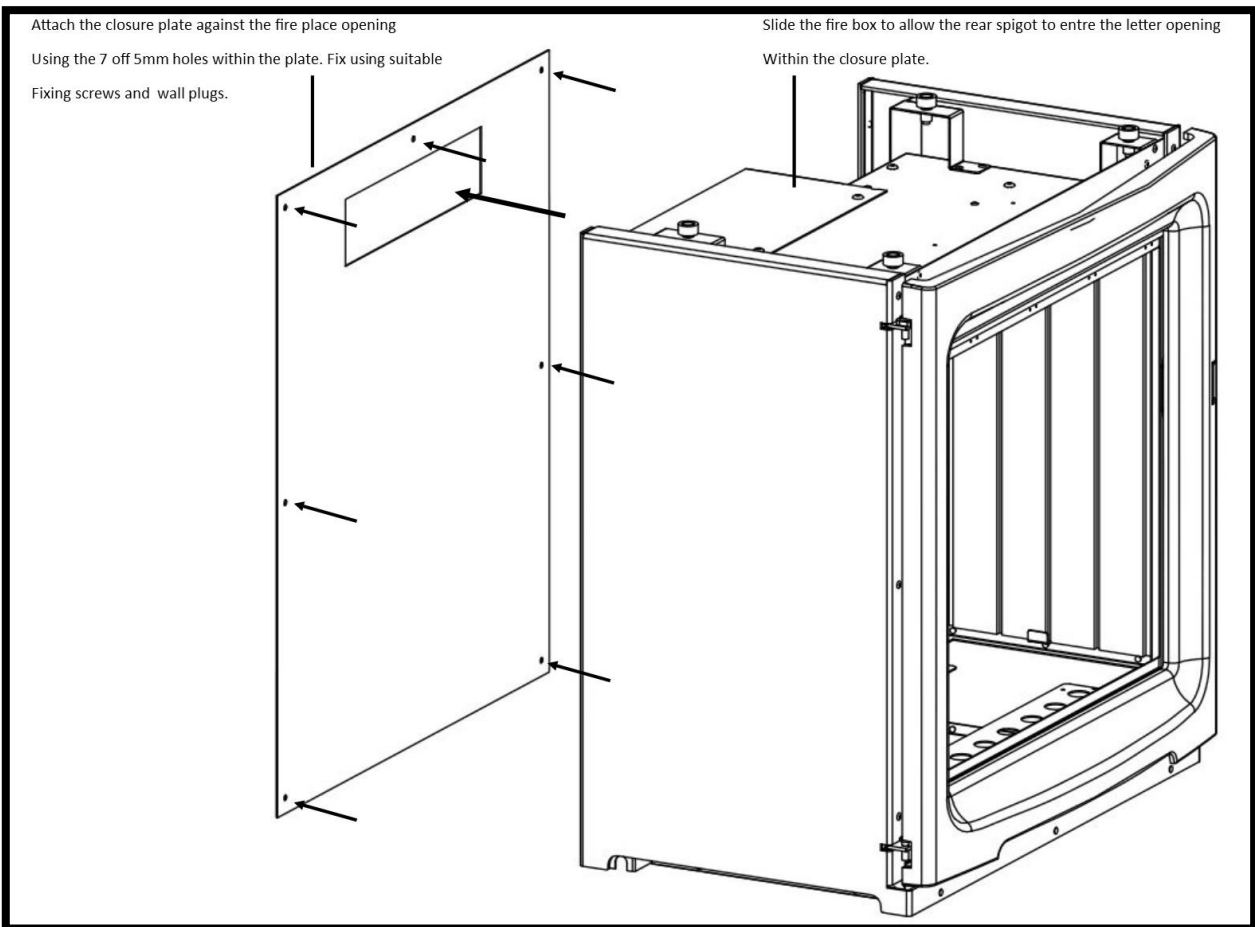
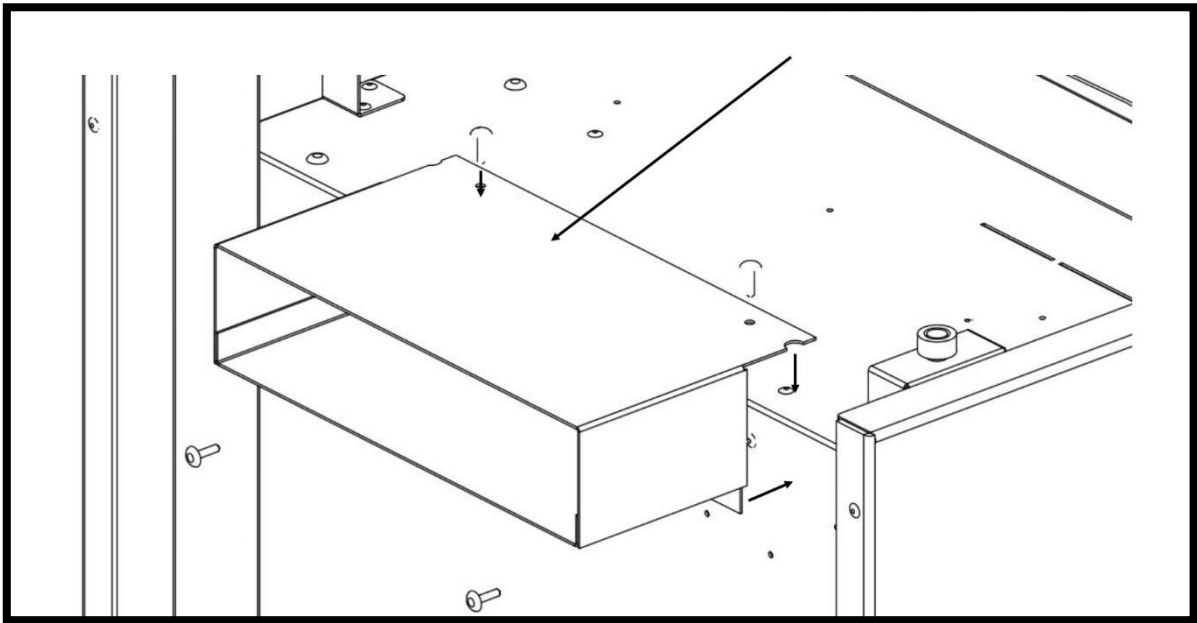

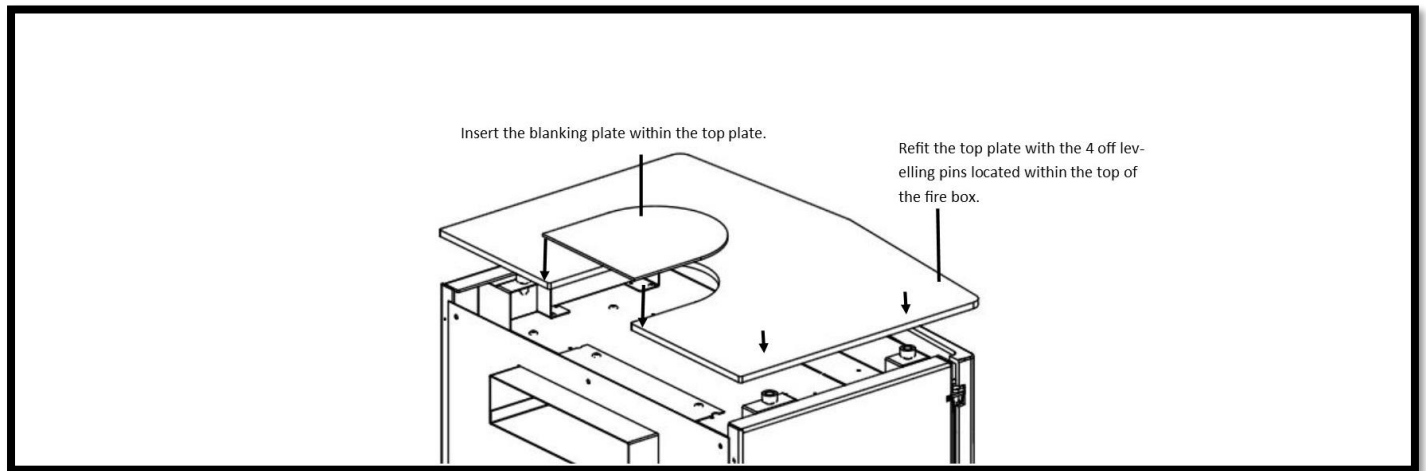

Note:- When installing the appliance using the above method. The appliance must sit hard against the closure plate. This will allow 50mm of the rear spigot assembly to protrude into the catchment area.

Rear Vent kit installation

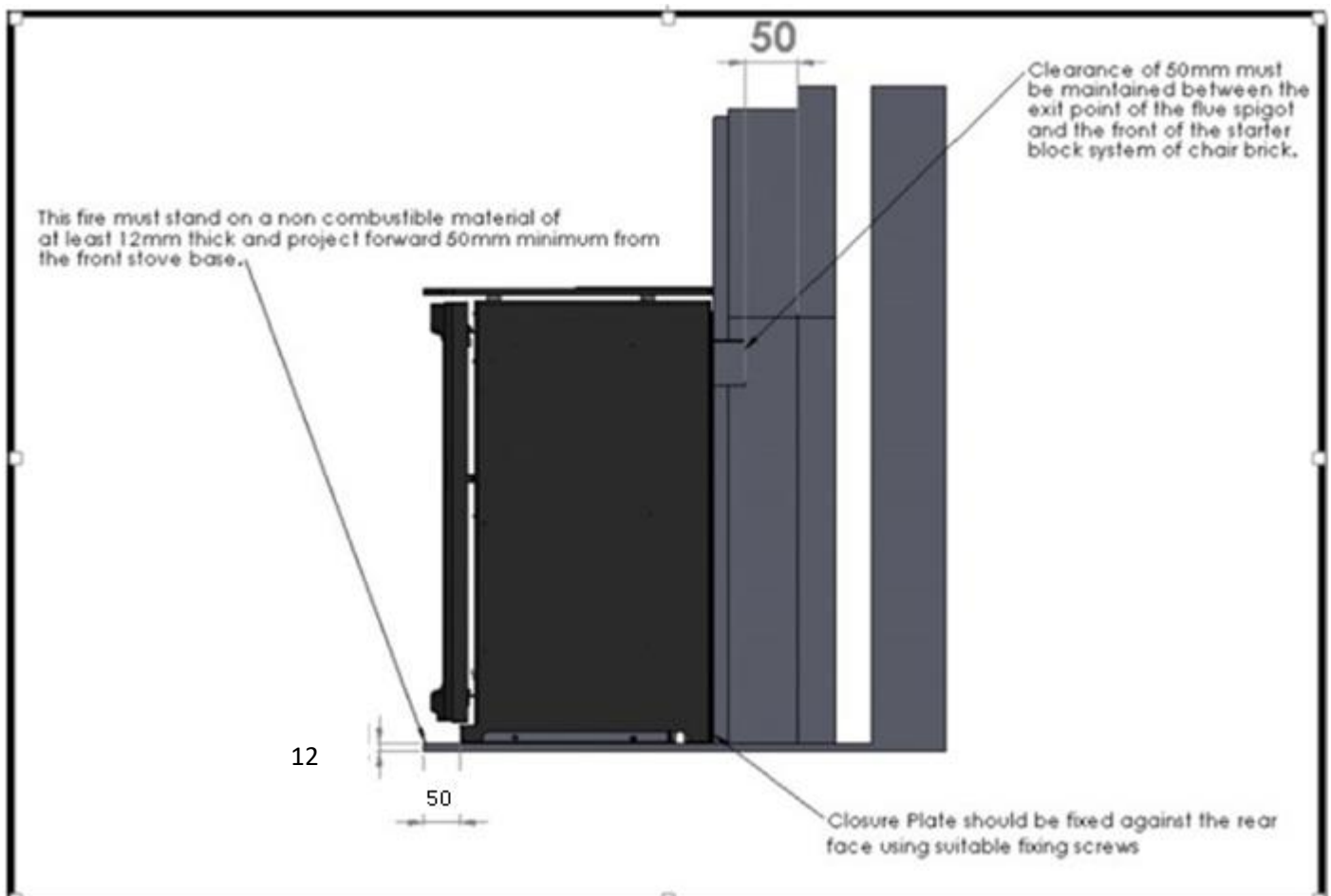

Non-combustible hearth requirements

The appliance must be fitted with a hearth that is 12mm high and projects 50mm to the front and sides. Minimum size of 506mm wide x 394mm deep x 12mm high.

Distances from Non-combustible materials:

The stove can be recessed in a suitable sized non-combustible fireplace but a permanent free air gap of at least 50mm must be left around the sides and top and at least 50 mm at the back of the stove to obtain reasonable heat output and for access to the stove for removal and maintenance.

Clearance requirements to a combustible material

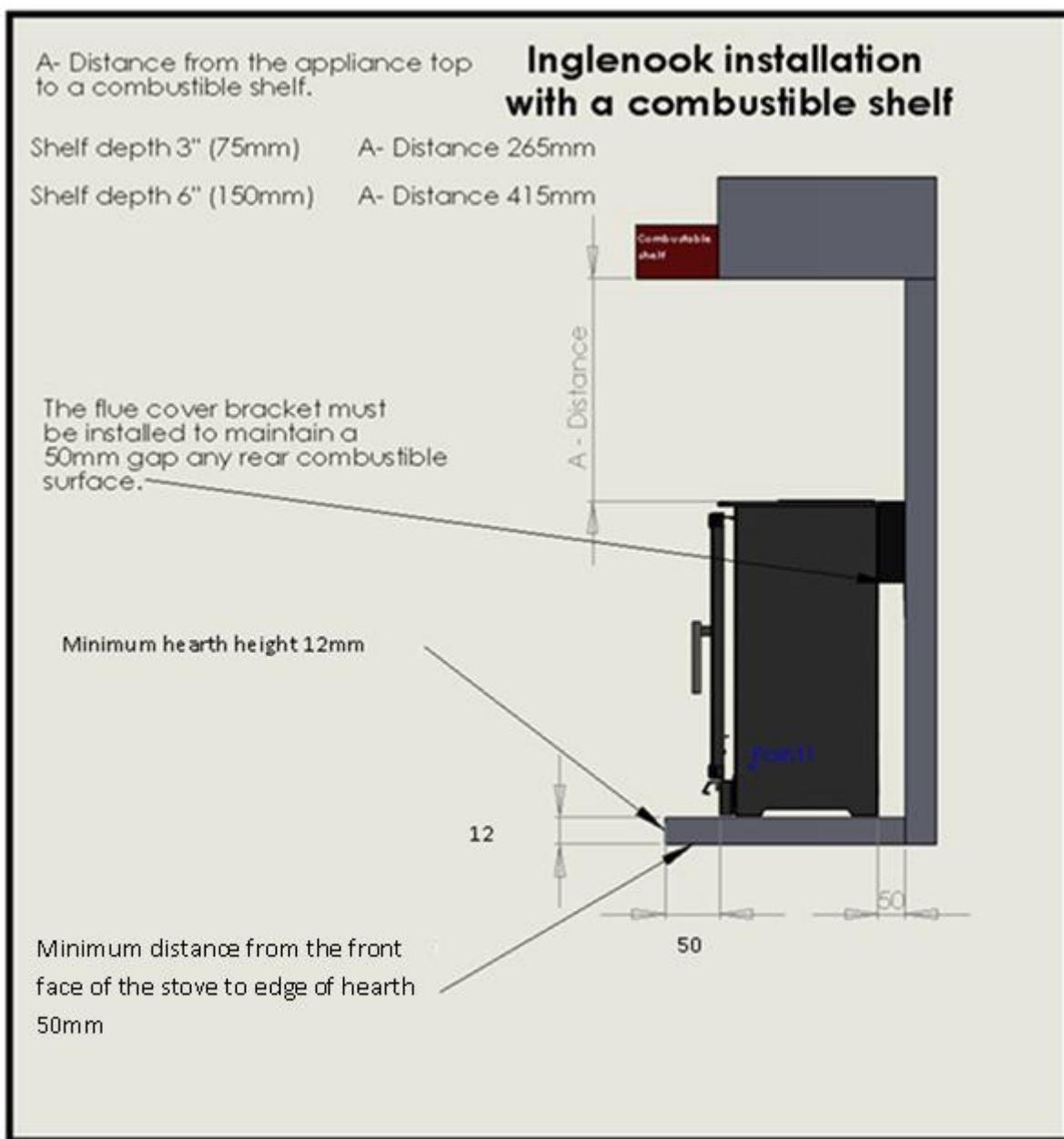



SECTION NINE To Install the Appliance (Installation Instructions)

CHECKING THE FLUE AND FIRE OPENING

- Check that the chimney conforms to the required specifications as previously stated. Examine the condition and carry out any remedial work including removing any debris from the base.
- If the flue has been used for solid fuel it should be swept prior to the installation
- Prior to installing the appliance a smoke test (using a smoke bomb) should be carried out to check that satisfactory smoke clearance has been established.

If all the smoke is not drawn into the flue, pre-heat the flue with a blowtorch or similar and re-check. If there is any uncertainty examine for the cause and, if necessary, seek expert advice.

No combustible material should be fitted inside the fireplace opening.

GAS SUPPLY ROUTING :-

Use rigid or semi – rigid tube to connect the supply. Determine the gas supply pipe route to the appliance before installing the Stove.

Check the gas run to assess that the gas supply is capable of providing the required amount of gas and is in accordance with the rules in force.

Soft copper pipe can be used to install the appliance. Soldered joints can be used only externally of the appliance.

The appliance is supplied with a factory fitted isolation device to allow for an 8mm copper connection. No further isolation point is required.

The new gas line must be purged of any debris, prior to final connection to the appliance.

Gas inlet isolation device is located on bottom left hand side of the fire box, the gas supply entry point is positioned at the rear bottom on left hand side. With the appliance fixing kit a 35mm round seal should be cut and fitted over the 8mm copper at the point the gas supply entry into the appliance assembly.

CHECKING GAS SOUNDNESS

Checking gas soundness and running pressure.

Turn on the supply to the appliance and check for soundness in accordance with the current codes of practice.

Turn off the gas supply at the external isolation valve.

Remove the pressure test point screw from the inlet elbow and connect the pressure gauge.

Turn on the gas to the appliance at the isolation valve.

Light the appliance as described in the user instruction section 2. Operating the appliance.

Check the inlet pressure is 20 mbar N.G. or 37 mbar LPG Propane +/- 1.0 mbar with other appliances running.

Turn off gas supply, at the isolation valve. Disconnect the pressure gauge and replace the pressure test point screw.

Turn on the appliance and check the pressure test point for soundness with detection fluid.

POWER LEAD ROUTING

The power supply for this appliance is provided via AC power adaptor 230 VAC. The main cable terminates at the rear Right hand side of the fire box. The length of the cable provided with the appliance is 1.65 metres. Care must be taken when siting the fire box not to trap the exposed main cable within the builders opening.

Note: the power cable link to the transformer must be accessible for repairing handset and use with the battery holder

The cable can be routed using the following two methods,

Method 1

Passing the cable through the side of the chimney breast. It is good practice to run the cable within a sleeve of at least 15mm internal diameter, sealing the sleeve using a suitable sealant at the point the sleeve / cable terminates the chimney masonry.

Method 2

Remove a channel out of the outer skin of the Dry / wet plaster of the chimney breast up to the main power point. Again it is good practice to run the cable within a sleeve of at least 15mm internal diameter.

With power points that exceed the 1.65 metre distance, an optional 2.0 metre extension cable is available Part No 7147.

The cable system consists of retro fitting plug sockets which offers the following options. (Please see figure 5).

The battery manual override option is a back supply in case of a power failure / power cut to the property. The battery holder and adaptor lead are provide as an optional extra. It is good practice to demonstrate the battery option to the customer during the commissioning process.

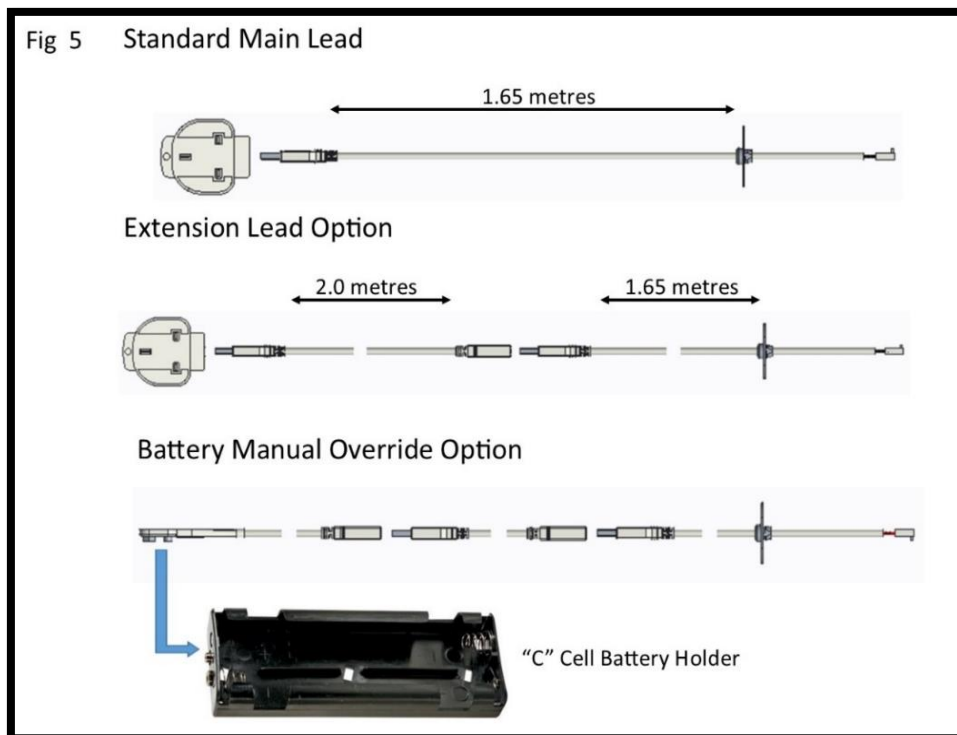

SECTION TEN Checking Operation of Fire (Installation Instructions)

Removing the Glass Panel

Remove Glass Panel.

Due to transit protection, the glass panel is packed fitted to the appliance. Special care should be taken when removing the glass panel from the appliance. The top fixing is attached to the fire box via 2 off M4 fixing nuts. Remove the nuts and remove the top fixing bracket to be able to remove the glass from the front of the appliance.

LAY FUEL BED

Important: -

Refer to the 'Heath & Safety Notice located on page 5 of this booklet before laying or replacing any refractory material.

In the event of replacing fuel bed components please use only the specified number of components as illustrated. Only use fuel bed component provided for this appliance. In the interest of safety and efficiency of your appliance when replacing the fuel bed it is essential that the existing fuel bed be removed and the new components are replaced correctly as a complete set.

Lay Log fuel bed as described under Users Section.

Warning:

It is important that the fuel bed components are positioned as shown in these instructions.

If the fuel bed components are not positioned correctly this may result in damage to the glass.

Once fuel bed is fitted refit the glass

Locate the glass panel within the bottom retaining slot and push back against the seals.

Position the top fixing bracket over the top edge of the glass panel and slide over the Two M4 studs.

Using the four M4 nuts previously removed. Tighten the top glass fixing using the nut runner provided with the appliance.

CHECKING FOR COMBUSTION PRODUCTS CLEARANCE

Spillage Test Procedure.

(Please note this test should be taken with the decorative door fully off)

Light the appliance on maximum setting.

Close all the doors and windows.

After five minutes fit the smoke match within match holder and position as illustrated in Figure 13 with the head of the match just inside the inlet air channel.

Run the match along the edge of the inlet air channel. All smoke must be drawn into the inlet channel if the spillage test is satisfactory.

If spillage occurs wait a further five minutes and repeat the test.

Repeat the test with doors open and with any extractor fans in other rooms in operation.

If spillage is detected the cause must be discovered and the fault corrected. If the fault cannot be corrected. Disconnect the fire from the gas supply and seek expert advice. Spillage can be caused by a restriction in the flue system, down draught or insufficient ventilation into the room where the fire is installed.

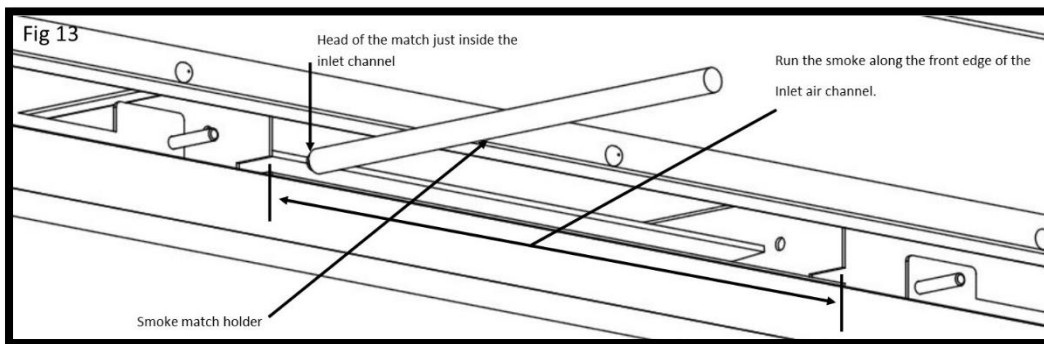

ADVISE CUSTOMER THAT:

- The glass front of this fire acts as a dress guard, conforming to BS 1945 (1997) and satisfies the heating appliance regulations (1991) however; a fireguard conforming to BS6539 (1997) must be used to protect young children, the elderly, or infirm.
- The curing effect of heating the coals and other refractory components will cause an initial odour. This is due to the starch used in the manufacturing process and is non-toxic.
- Any debris should be cleaned from the appliance. A vacuum cleaner can be used but only after all the loose log shapes and vermiculite has been removed.
- The appliance should be serviced annually by a competent person in accordance with these instructions and the appliance checked for spillage in accordance with the method detailed in these instructions.
- Demonstrate the lighting and extinguishing procedures to the user. Refer to the user section of this booklet.
- If ventilation is fitted for any reason it must be checked regularly to ensure freedom from obstructions.

Hand these instructions over to the user.

SECTION ELEVEN Maintenance (Maintenance Instructions)

GENERAL

- Servicing should be carried out annually by a competent person such as a Gas Safe-registered person in accordance with the relevant regulations, to ensure the safe and correct operation of the appliance.
- Before commencing any service or replacement of parts, turn off the gas supply to the fire. After servicing check for gas soundness.
- When ordering spare parts please quote appliance name and serial number, these can be found on the data badge, which is located on the rear of the door of the appliance.
- At least once a years check for debris in the catchment area behind the fire and in the flue way.
- If soot has accumulated checks to establish cause rectify and clean flue or chimney accordingly.

To Remove The Burner Carrier Assembly

Turn off the main supply to the appliance.

Remove or lift up top plate.

Remove the decorative door assembly.

Remove the glass panel.

Remove the Loose shapes .

Shut off the restrictor elbow and disconnect the 8mm inlet nut.

Take out the two screws securing the burner carrier assembly to the Firebox.

Pull the complete burner carrier assembly forward until it clears the firebox guide brackets. (Please note the mains supply cable will need to be disconnected from the ECU Unit).

Replacement Of The Gas Valve

Follow the sequence to remove the burner carrier assembly.

Disconnect the thermocouple from the rear of the gas valve.

Undo the three compression nuts securing the pipes to the gas valve and remove the two M4 nuts fixing the valve to the valve mounting brackets.

Clean, service or replace the gas valve.

Re-assemble in the reverse order.

Turn on the gas supply, check for soundness and re-commission the appliance.

Replacement Of The Injector

Follow the sequence to remove the burner carrier assembly.

Undo the compression nut on the supply pipe.

Remove the two screws retaining the burner assembly to the carrier and lift away from the injector.

Unscrew the locking nut holding the injector and silencer bracket on the burner carrier.

Remove injectors from assembly. Clean or replace injector.

Re-assemble in reverse order.

Replacement of the Oxy-Pilot Assembly

Note: If the pilot assembly is replaced it must be replaced by an identical unit from the same manufacturer and replaced as a complete unit.

Follow the sequence to remove the burner carrier assembly.

Undo the compression nut on the supply pipe at the pilot.

Carefully pull off the ignition lead.

Disconnect the thermocouple at the end of the gas valve.

Remove the two fixing screws attaching the assembly to burner carrier.

Re-assemble in the reverse order.

Replacement of the burner Assembly

Remove the glass panel as described in the users instruction section.

Remove the Loose shapes and the air tray assembly.

Undo the three fixing screws retaining the burner assembly with the carrier.

Lift the burner clear of the silencer and injector tip.

Clean or replace the burner assembly.

Re-assemble in reverse order.

Replacement of the Electronic Control Unit (ECU)

Remove the glass panel as described in the users instruction section.

Remove the Loose shapes and the air tray assembly.

Remove the burner carrier assembly.

Undo the one M3 nuts retaining the ECU unit.

Unplug the connection from the ECU board.

Re-assemble in reverse order.

Replacement Handset

Follow the guide stipulated on page 7 of the users instructions "Changing the handset batteries" to load the batteries into the new handset.

Re-Pairing the handset or ECU unit

When replacement handset or ECU the two items will need to be re-paired using the following procedure.

To start the pairing process, you will need to break the jack plug connection (this is where the lead from the transformer plug meets the mains lead) shown below.



Make sure that the remote handset has batteries installed then turn the power on to the appliance on.

Within 30 seconds of power on, press any button on the remote handset.

The LED on the handset will start to flash quickly indicating the pairing process has started. If successful pairing is achieved then the LED will show 5 slow flashes. If pairing fails there will be 3 long flashes.

If this happens then remove power to the appliance and repeat the pairing process.

Register your appliance online today to active your warranty



GAS FIRE COMMISSIONING CHECKLIST

This Commissioning Checklist is to be completed in full by the competent person who commissioned the gas fire as a means of demonstrating compliance with the appropriate Building Regulations and then handed to the customer to keep for future reference.

Failure to install and commission according to the manufacturer's instructions and complete this Benchmark Commissioning Checklist will invalidate the warranty. This does not affect the customer's statutory rights.

Site Requirements	Yes	N/A
Was the chimney checked to ensure it only serves one flue/fire, has no obstructions and is continuous?		
Has any debris at the base of the chimney been removed?		
For brick chimney installations is there enough depth for 12 litres of debris, or precast flues 2 litres of debris? (see instructions for debris gap details)		
Have damper and register plates been removed or locked in the fully open position ensuring correct size of flue is maintained?		
If previously used for solid fuel has the chimney been thoroughly swept?		
If the chimney is pre-cast has the inside of the flue been checked for extruded cement / sealant which must be removed?		
Has the fire place been checked for under-floor air supply which must be sealed off?		
Has the chimney been inspected prior to fitting the gas fire to ensure that it is in good condition?		
Has the structure of the chimney been checked for leakage using a smoke pellet test? (See BS5440-1 for details).		
Ventilation		
Does the installation require any additional ventilation requirements as detailed in the manufacturer's instructions?		
Hearth Requirements- where fitted		
Is the hearth constructed from non -combustible material?		
Is the hearth a minimum of 12mm thick with a minimum floor to top surface of 50mm?(BS5871) or as per manufacturer's instructions?		
Is the hearth for open fronted fires a minimum of 760mm wide and has 300mm projecting from the fire opening (BS6871) or to manufacturer's instructions?		
Mounting height (where applicable) has the fire been installed to the correct mounting height- as per manufacturer's instructions?		
Firebox and Fuel Bed		
Has the fuel bed, coals, pebbles etc. been fitted to manufacturer's instructions?		
Gas Supply		
Has an isolation tap/restrictor inlet elbow been fitted for servicing?		
Has the gas supply been thoroughly purged prior to connection to remove any debris?		
Has a gas tightness test been completed prior to breaking into the gas supply and following completion of installation?(IGEM/UP/1B)		
Record burner gas pressure reading? If only the supply pressure is available a gas rate must be undertaken.(GSIUR REG26/9C)		
Record dynamic inlet gas pressure (working pressure) reading (all gas appliances running)		
Spillage test		
Installation passes smoke match test with any extractor fans turned on (see manufacturer's instructions)		
Installation		
Has the gas fire been installed and commissioned in accordance with manufacturer's instructions?		
Has the fire been installed with the correct clearance to combustible materials, as per manufacturer's instructions?		
The operation of the appliance and controls have been demonstrated to the customer including battery replacement where applicable?		
The manufacturer's literature, including Benchmark Checklist and Service record has been explained and left with the customer?		
Has the appliance been registered with the Local Authority as detailed on the Gas Safe web site and is a legal requirement and forms part of the warranty?		
Customer's Signature: (To confirm satisfactory demonstration and receipt of manufacturer's literature)	Commissioning Engineer's Signature:	

*All installations in England and Wales must be notified to be Local Authority Building Control (LABC) either directly or through a Competent Persons Scheme. A Building Regulations Compliance Certificate will then be issued to the customer.

SERVICE RECORD

It is essential that your gas fire is serviced regularly and that the appropriate Service Interval Record is completed. Service Provider

Before completing the appropriate Service Record below, please ensure you have carried out the service as described in the manufacturer's instructions. Always use the manufacturer's specified spare part when replacing controls.

SERVICE 01	Date:
Engineer name:	
Company name:	
Telephone No:	
Gas safe register No:	
Comments:	
Signature	

SERVICE 02	Date:
Engineer name:	
Company name:	
Telephone No:	
Gas safe register No:	
Comments:	
Signature	

SERVICE 03	Date:
Engineer name:	
Company name:	
Telephone No:	
Gas safe register No:	
Comments:	
Signature	

SERVICE 04	Date:
Engineer name:	
Company name:	
Telephone No:	
Gas safe register No:	
Comments:	
Signature	

SERVICE 05	Date:
Engineer name:	
Company name:	
Telephone No:	
Gas safe register No:	
Comments:	
Signature	

Product ID Label	A-0770	Serial No Prefix	SV	N.G.
	A-0863		UE	
	A-1013		TL	
	A-0827			
Burner Tray / Box Assembly				
Restrictor Elbow (Part No 2189)				
Log Fuel Bed				
Glass Panel (Part No 8113)				
Data Badge / Spillage Label (10 minute text)				
Warning Label (Part No 1409)				
ID Label & Packing Labels				
Owners Book				
2 x AAA Batteries (Part No 5487)				
Embaglow				
7MM Nut Spinner (Part No 5435)				
Remote Handset (Bluetooth Part No 8081)				
9v Transformer (Part No 7145)				
Spigot Gasket				
Flue Spigot				
Grommet (solid) 35mm (1092)				
Serial Number				
Inspector				